

E Z

C U T

> YOUR BEST PARTNER TO WORK WITH !

Introduction

Sen Yeong Precision Tool Co. is a professional manufacturer of carbide tipped Router Bits and Shaper Cutters. The company was founded in 1965. Over these 34 years, we have continued growing, improving, and accumulating experiences and skills.



In the production processes, we enforce a fine quality assurance system and are accredited by ISO 9002 in 1997. Therefore, durability and stability of our products are guaranteed. We are confident of meeting your quality requests and being a supplier you can rely on.



EZCUT[®] is our new brand name. You can recognize us easily. **EZCUT**[®] reveals our insistence on quality and our energetic, creative spirit. Give us a try, we can be your best partner to work with !

S P M



Product and Quality

Varied grades of products are available.
Standard Good quality with competitive prices.
Premium Better Stability & Higher Durability.
Micrograin Micrograin carbide and better steel make products of Superior Quality.













OUR QUALITY POLICY

EXCELLENT QUALITY * FAST DELIVERY * SATISFIED CUSTOMER

index

	Straight Bit (1, 2, 3, 15)	
	0096-0202	1
	0011-0043	
	0071	
	0001-0003	2
	0166-0260	
	0151-0244	
	0081-0089	
	0136-0138	3
	0139-0228	
	0276-0287	15
	Flush Trimming Bit (3, 4)	
	1511-1542	3
	1571-1592	
	1610	4
	1631	
	1651	
	1671	
	Chamfer Bit (5)	
	0786-0824	5
	Roundover Bit (6, 7, 15)	
	0356-0411	6
	0556	7
	0351	15
	Solid Surface Bit (5, 6)	
	0851-0852	5
	0811	
	0866-0867	
	0881	6
	Handrail Bit Set (7)	
	0441-0442	7
	0451-0453	
	Beading Bit (6, 17)	
	0516-0568	6
	1011	17
	Cove Bit (7)	
	0891-0942	7
	Dovetail Bit (8, 14)	
	0666-0716	8
	0326	14
	Rabbeting Bit (8, 9)	
	0461-0492	8
	1366-1416	
	1396-1441	9
	1361-1362	

	Core Box Bit (8, 10, 14)	
	1261-1293	9
	1276-1307	
	1321-1340	10
	0336	14
	Roman Ogee Bit (10)	
	1161-1192	10
	1186	
	Plunge Bit (7, 10, 11, 13, 14, 20)	
	0736-0769	10
	0756-0761	11
	2111-2128	
	1961-1994	
	1981-1986	
	2101-2106	7
	2141-2151	
	0296-0301	13
	0306-0311	14
	0926-0931	20
	Bull Nose Bit (12)	
	1111-1145	12
	1051-1090	
	V-Groove Bit (13, 14)	
	1711-1743	13
	0316	14
	Tongue & Groove (15, 16)	
	0596	15
	0606	
	0616	16
	0626-0627	
	Lock Miter Bit (16, 19)	
	0636-0637	16
	0641-0646	
	1836-1847	19
	Finger Joint Bit (17)	
	0651	17
	0661	
	Edge Beading Bit (18)	
	2161-2173	18
	2181-2182	
	2201-2212	
	2221-2244	
	Flute & Bead Set (19)	
	1221-1232	19

	Keyhole Bit (20, 8)	
	0916-0917	20
	0511	8
	Panel Pilot Bit (20)	
	1241-1252	20
	Moulding Bit (6, 19, 20, 21, 22, 23, 24)	
	1461	20
	1476	21
	1491	
	1756-1772	
	1806-1821	
	1856-1872	22
	1906-1921	
	1796	
	1946-1948	
	2266-2286	23
	2326-2328	
	2341-2343	
	2401-2404	
	2441	24
	2442	
	1021-1038	19
	0436	6
	Hinge Boring Bit (24)	
	2801-2805	24
	Raised Panel Bit (25)	
	2471-2512	25
	2551-2571	
	Rosettee Cutter (26)	
	2871-2880	26
	Stile & Rail (26, 27, 28)	
	2591-2621	26
	2013-2058	27
	2661-2701	
	2781-2782	28
	Window Sash Set (28)	
	2741-2742	28
	2751-2752	
	Radius Bit (13)	
	0961-0980	13
	0991-0996	
	Finger Pull Bit & Door Lip Bit (17, 19)	
	1006-1007	17
	1886-1888	19

0096

Straight Bits
2 Flutes

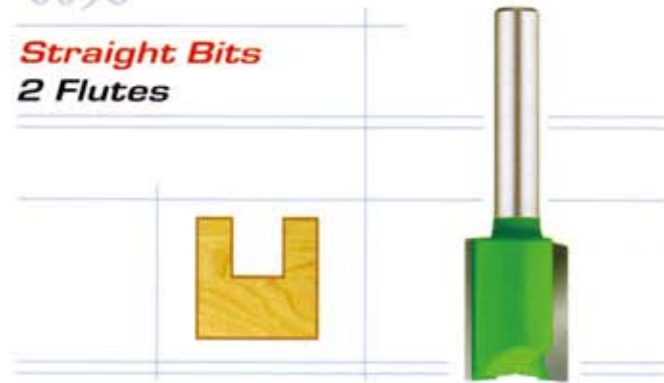

ITEM NO.	SHANK DIA.	CUTTER DIA.	CUTTING LENGTH	OVERALL LENGTH
0096	1/4"	1/4"	3/4"	2"
0097	1/4"	5/16"	3/4"	2"
0098	1/4"	3/8"	3/4"	2"
0099	1/4"	1/2"	3/4"	2"
0100	1/4"	5/8"	3/4"	2"
0101	1/4"	23/32"	3/4"	2"
0102	1/4"	3/4"	3/4"	2"
0103	1/4"	1"	3/4"	2"
0186	1/2"	1/4"	3/4"	2-1/4"
0187	1/2"	5/16"	3/4"	2-1/4"
0188	1/2"	3/8"	3/4"	2-1/4"
0189	1/2"	7/16"	1"	2-1/2"
0190	1/2"	1/2"	1-3/16"	2-11/16"
0191	1/2"	1/2"	2"	3-1/2"
0192	1/2"	5/8"	1-3/16"	2-11/16"
0193	1/2"	5/8"	2-3/8"	4"
0194	1/2"	11/16"	1-3/16"	2-11/16"
0195	1/2"	23/32"	1-3/16"	2-11/16"
0196	1/2"	3/4"	1-3/16"	2-11/16"
0197	1/2"	3/4"	2"	3-1/2"
0198	1/2"	1"	1-3/16"	2-11/16"
0199	1/2"	1-3/16"	2"	3-1/2"
0200	1/2"	1-1/4"	1-3/16"	2-11/16"
0201	1/2"	1-3/8"	1-3/16"	2-11/16"
0202	1/2"	1-5/8"	1-3/16"	2-11/16"

0001

Inserted Solid Carbide Straight Bits
1 Flute

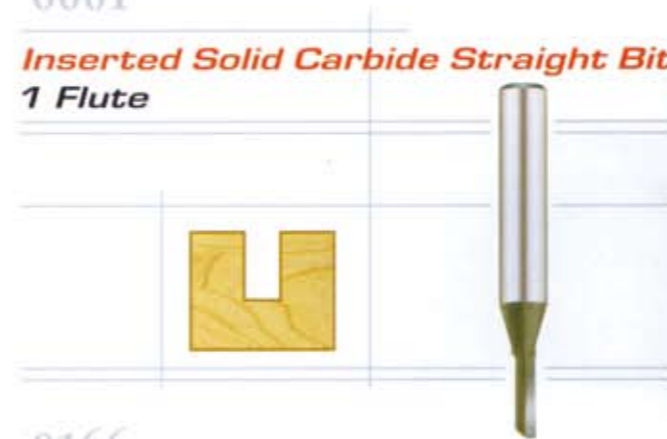

ITEM NO.	SHANK DIA.	CUTTER DIA.	CUTTING LENGTH	OVERALL LENGTH
0001	1/4"	1/8"	3/8"	1-3/4"
0002	1/4"	5/32"	3/8"	1-3/4"
0003	1/4"	3/16"	3/8"	1-3/4"

0166

Bottom Cleaning Straight Bits
2 Flutes



ITEM NO.	SHANK DIA.	CUTTER DIA.	CUTTING LENGTH	OVERALL LENGTH
0166	1/4"	3/8"	3/4"	2"
0167	1/4"	1/2"	3/4"	2"
0168	1/4"	5/8"	3/4"	2"
0169	1/4"	3/4"	3/4"	2"
0170	1/4"	7/8"	3/4"	2"
0256	1/2"	3/8"	1"	2-1/2"
0257	1/2"	1/2"	1"	2-1/2"
0258	1/2"	5/8"	1"	2-1/2"
0259	1/2"	3/4"	1"	2-1/2"
0260	1/2"	1"	1"	2-1/2"

0151

Shear Cut Straight Bits
2 Flutes



Cutting edge is angled.

ITEM NO.	SHANK DIA.	CUTTER DIA.	CUTTING LENGTH	OVERALL LENGTH
0151	1/4"	1/4"	3/4"	2"
0152	1/4"	3/8"	3/4"	2"
0153	1/4"	1/2"	3/4"	2"
0241	1/2"	1/4"	3/4"	2-3/4"
0242	1/2"	3/8"	1"	2-3/4"
0243	1/2"	1/2"	1-1/8"	2-7/8"
0244	1/2"	3/4"	1-1/8"	2-7/8"

0081

Straight Bits
With Extended Shank Length



ITEM NO.	SHANK DIA.	CUTTER DIA.	CUTTING LENGTH	OVERALL LENGTH
0081	1/4"	5/16"	1"	2-3/4"
0088	1/2"	7/16"	7/8"	3"
0089	1/2"	1/2"	7/8"	3"

0011

Straight Bits
1 Flute

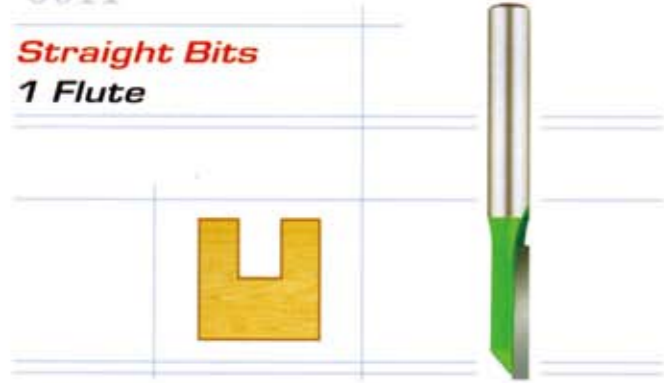

ITEM NO.	SHANK DIA.	CUTTER DIA.	CUTTING LENGTH	OVERALL LENGTH
0011	1/4"	1/8"	3/8"	1-7/8"
0012	1/4"	5/32"	3/8"	1-1/2"
0013	1/4"	3/16"	3/8"	1-7/8"
0014	1/4"	1/4"	3/4"	2-1/8"
0015	1/4"	3/8"	3/4"	2"
0016	1/4"	1/2"	3/4"	2"
0041	1/2"	1/4"	3/4"	2-5/8"
0042	1/2"	3/8"	1"	2-3/4"
0043	1/2"	1/2"	1-1/8"	2-3/4"

0071

Inserted Solid Carbide Straight Bit
2 Flutes

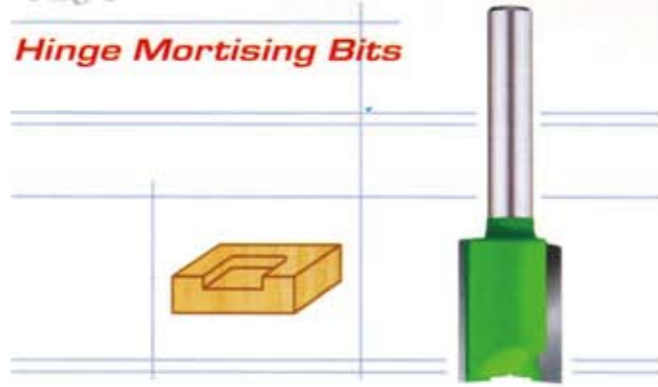

0136

Hinge Mortising Bits

0139

Bottom Cleaning Bits

1511

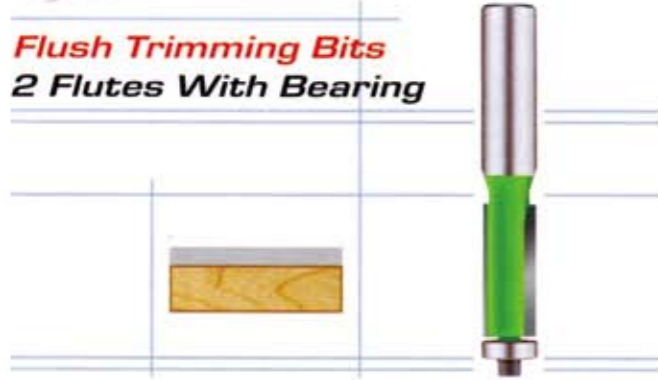
**Flush Trimming Bits
2 Flutes With Bearing**

1571

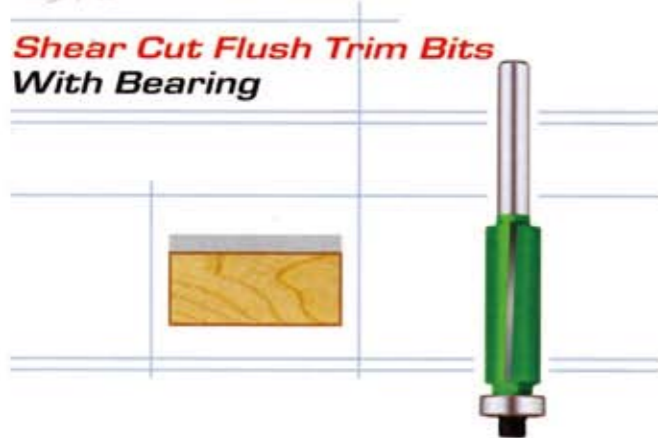
**Shear Cut Flush Trim Bits
With Bearing**

Cutting edge is angled.

ITEM NO.	SHANK DIA.	CUTTER DIA.	CUTTING LENGTH	OVERALL LENGTH
0136	1/4"	1/2"	3/4"	2"
0137	1/4"	5/8"	3/4"	2"
0138	1/4"	3/4"	3/4"	2"

ITEM NO.	SHANK DIA.	CUTTER DIA.	CUTTING LENGTH	OVERALL LENGTH
0139	1/4"	3/4"	9/16"	2"
0226	1/2"	3/4"	9/16"	2-1/4"
0227	1/2"	1"	7/16"	2-1/4"
0228	1/2"	1-1/2"	7/16"	2-1/4"

ITEM NO.	SHANK DIA.	CUTTER DIA.	CUTTING LENGTH	SHANK LENGTH
1511	1/4"	3/8"	1-1/8"	1-1/4"
1512	1/4"	1/2"	15mm	1-1/4"
1513	1/4"	1/2"	1-1/8"	1-1/4"
1514	1/4"	5/8"	1-1/8"	1-1/4"
1541	1/2"	1/2"	1-1/8"	1-1/2"
1542	1/2"	5/8"	1-1/8"	1-1/2"

ITEM NO.	SHANK DIA.	CUTTER DIA.	CUTTING LENGTH	SHANK LENGTH
1571	1/4"	1/2"	1-1/8"	1-1/4"
1572	1/4"	5/8"	1-1/8"	1-1/4"
1591	1/2"	1/2"	1-1/8"	1-1/2"
1592	1/2"	5/8"	1-1/8"	1-1/2"

1610

**Flush Trim "V" Groove Bit
With Bearing**

1631

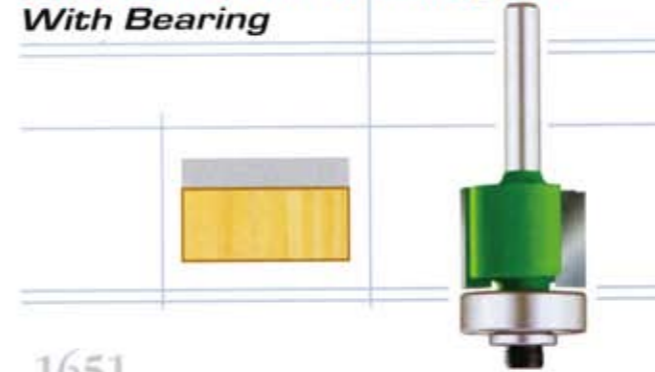
**Laminate Flush Trimming Bit
With Bearing**

1651

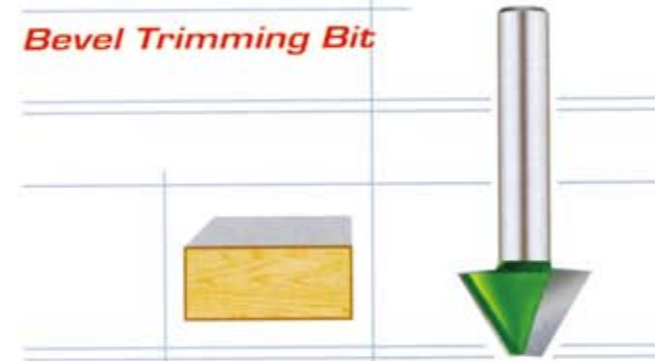
Bevel Trimming Bit

1671

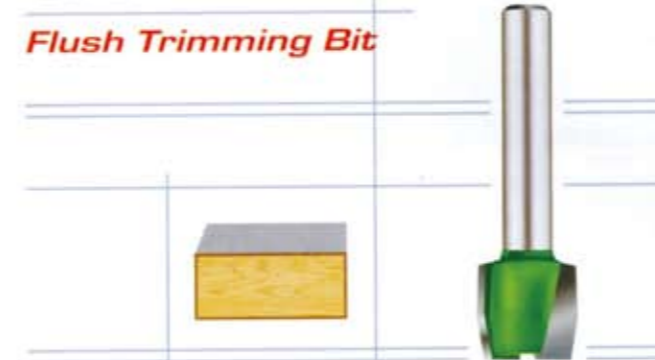
Flush Trimming Bit

ITEM NO.	SHANK DIA.	CUTTER DIA.	CUTTING LENGTH	SHANK LENGTH	BEARING DIA.
1610	1/4"	5/8"	1-3/16"	1-1/4"	1/2"

ITEM NO.	SHANK DIA.	CUTTER DIA.	CUTTING LENGTH	SHANK LENGTH
1631	1/4"	22mm	5/8"	1-1/4"

ITEM NO.	SHANK DIA.	CUTTER DIA.	CUTTING LENGTH	SHANK LENGTH	ANGLE
1651	1/4"	5/8"	1/2"	1-1/4"	30°

ITEM NO.	SHANK DIA.	CUTTER DIA.	CUTTING LENGTH	SHANK LENGTH	ANGLE
1671	1/4"	1/2"	7/16"	1-1/4"	22°

3

T.C.T. ROUTER BITS

4

T.C.T. ROUTER BITS

0786

**Chamfer Bits
With Bearing**



ITEM NO.	SHANK DIA.	CUTTER DIA.	CUTTING LENGTH	BEVEL LENGTH	ANGLE
0786	1/4"	1"	3/8"	1/4"	45°
0787	1/4"	1-3/8"	5/8"	7/16"	45°
0788	1/4"	3/4"	1/2"	-	15°
0789	1/4"	7/8"	1/2"	-	25°
0816	1/2"	1-1/8"	1/2"	3/8"	45°
0817	1/2"	1-3/8"	5/8"	7/16"	45°
0818	1/2"	1-5/8"	3/4"	1/2"	45°
0819	1/2"	1-7/8"	7/8"	5/8"	45°
0820	1/2"	2-1/8"	1-1/8"	3/4"	45°
0821	1/2"	7/8"	1"	-	11.25°
0822	1/2"	1"	1"	-	15°
0823	1/2"	1-1/4"	1"	-	22.5°
0824	1/2"	1-1/2"	7/8"	-	30°

0851

**Bevel Bowl Bits
With Bearing**

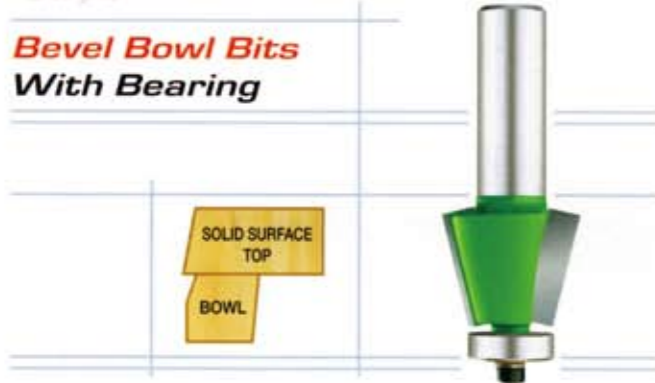

ITEM NO.	SHANK DIA.	CUTTER DIA.	CUTTING LENGTH	SHANK LENGTH	ANGLE
0851	1/2"	1"	3/4"	1-1/2"	15°
0852	1/2"	1-1/4"	1"	1-1/2"	10°

0811

**Ogee Bowl Bits
With Bearing**



ITEM NO.	SHANK DIA.	CUTTER DIA.	CUTTING LENGTH	SHANK LENGTH	ANGLE
0811	1/2"	2-1/4"	1-1/4"	1-1/2"	10°

0866

**No-Drip Edge Bits
With Bearing**



ITEM NO.	SHANK DIA.	CUTTER DIA.	CUTTING LENGTH	SHANK LENGTH
0866	1/2"	13/16"	3/4"	1-1/2"
0867	1/2"	13/16"	7/8"	1-1/2"

0881

**Round Edge Bit
With Bearing**



ITEM NO.	SHANK DIA.	CUTTER DIA.	CUTTING LENGTH	SHANK LENGTH	RADIUS
0881	1/2"	1-5/8"	3/4"	1-1/2"	13/32"

0356

**Roundover Bits
With Bearing**



ITEM NO.	SHANK DIA.	CUTTER DIA.	CUTTING LENGTH	SHANK LENGTH	RADIUS
0356	1/4"	5/8"	3/8"	1-1/4"	1/16"
0357	1/4"	3/4"	3/8"	1-1/4"	1/8"
0358	1/4"	7/8"	3/8"	1-1/4"	3/16"
0359	1/4"	1"	1/2"	1-1/4"	1/4"
0360	1/4"	1-1/8"	1/2"	1-1/4"	5/16"
0361	1/4"	1-1/4"	5/8"	1-1/4"	3/8"
0362	1/4"	1-1/2"	3/4"	1-1/4"	1/2"
0401	1/2"	3/4"	3/8"	1-1/2"	1/8"
0402	1/2"	7/8"	3/8"	1-1/2"	3/16"
0403	1/2"	1"	1/2"	1-1/2"	1/4"
0404	1/2"	1-1/8"	1/2"	1-1/2"	5/16"
0405	1/2"	1-1/4"	5/8"	1-1/2"	3/8"
0406	1/2"	1-1/2"	3/4"	1-1/2"	1/2"
0407	1/2"	1-3/4"	7/8"	1-1/2"	5/8"
0408	1/2"	2"	1"	1-1/2"	3/4"
0409	1/2"	2-1/4"	1-1/8"	1-1/2"	7/8"
0410	1/2"	2-1/2"	1-1/4"	1-1/2"	1"
0411	1/2"	3"	1-1/2"	1-1/2"	1-1/4"

0436

**Thumbnail
With Bearing**

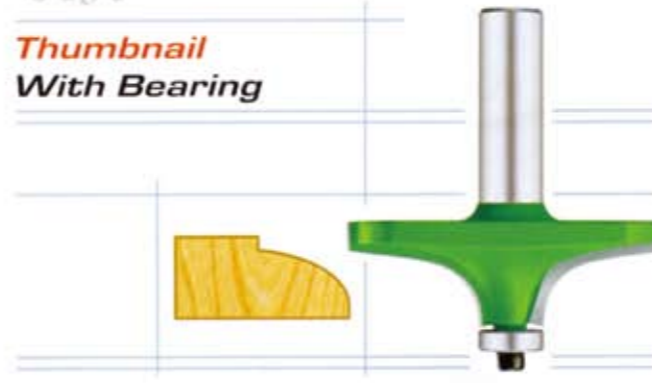

ITEM NO.	SHANK DIA.	CUTTER DIA.	CUTTING LENGTH	SHANK LENGTH	CUTTING WIDTH
0436	1/2"	2-1/2"	7/8"	1-1/2"	1"

0516

**Beading Bits
With Bearing**

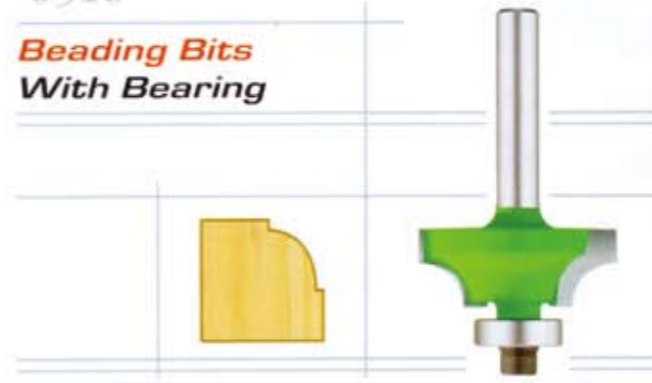

ITEM NO.	SHANK DIA.	CUTTER DIA.	CUTTING LENGTH	SHANK LENGTH	RADIUS
0516	1/4"	3/4"	3/8"	1-1/4"	1/16"
0517	1/4"	7/8"	3/8"	1-1/4"	1/8"
0518	1/4"	1"	3/8"	1-1/4"	3/16"
0519	1/4"	1-1/8"	1/2"	1-1/4"	1/4"
0520	1/4"	1-1/4"	1/2"	1-1/4"	5/16"
0521	1/4"	1-3/8"	5/8"	1-1/4"	3/8"
0522	1/4"	1-5/8"	3/4"	1-1/4"	1/2"
0561	1/2"	7/8"	3/8"	1-1/2"	1/8"
0562	1/2"	1"	3/8"	1-1/2"	3/16"
0563	1/2"	1-1/8"	1/2"	1-1/2"	1/4"
0564	1/2"	1-1/4"	1/2"	1-1/2"	5/16"
0565	1/2"	1-3/8"	5/8"	1-1/2"	3/8"
0566	1/2"	1-5/8"	3/4"	1-1/2"	1/2"
0567	1/2"	1-7/8"	7/8"	1-1/2"	5/8"
0568	1/2"	2-1/8"	1"	1-1/2"	3/4"

0441

**Handrail Bits & Finger Grip Bits
With Bearing**

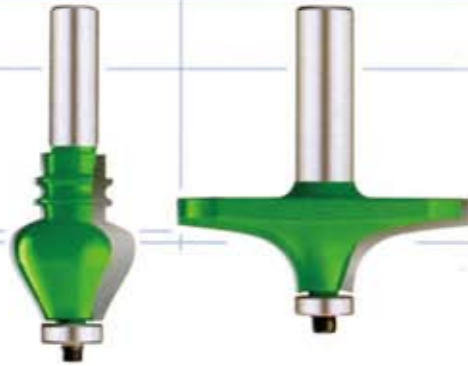

• Handrail Bits

ITEM NO.	SHANK DIA.	CUTTER DIA.	CUTTING LENGTH	SHANK LENGTH
0441	1/2"	2-3/4"	1-1/8"	1-1/2"
0442	1/2"	3-1/8"	1-1/8"	1-1/2"

• Finger Grip Bits

ITEM NO.	SHANK DIA.	CUTTER DIA.	CUTTING LENGTH	SHANK LENGTH
0451	1/2"	1-1/8"	1-1/2"	1-1/2"
0452	1/2"	1-1/4"	1-1/2"	1-1/2"
0453	1/2"	1-1/4"	1-1/2"	1-1/2"

0556

**Double Roundover Bit
With Bearing**



0891

**Cove Bits
With Bearing**

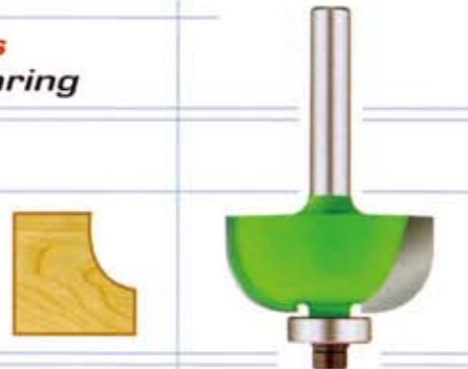

ITEM NO.	SHANK DIA.	CUTTER DIA.	CUTTING LENGTH	SHANK LENGTH	RADIUS
0556	1/2"	1-1/4"	1-1/8"	1-1/2"	3/16"

ITEM NO.	SHANK DIA.	CUTTER DIA.	CUTTING LENGTH	SHANK LENGTH	RADIUS
0891	1/4"	5/8"	3/8"	1-1/4"	1/16"
0892	1/4"	3/4"	1/2"	1-1/4"	1/8"
0893	1/4"	7/8"	1/2"	1-1/4"	3/16"
0894	1/4"	1"	1/2"	1-1/4"	1/4"
0895	1/4"	1-1/8"	1/2"	1-1/4"	5/16"
0896	1/4"	1-1/4"	5/8"	1-1/4"	3/8"
0897	1/4"	1-1/2"	5/8"	1-1/4"	1/2"
0936	1/2"	3/4"	1/2"	1-1/2"	1/8"
0937	1/2"	7/8"	1/2"	1-1/2"	3/16"
0938	1/2"	1"	1/2"	1-1/2"	1/4"
0939	1/2"	1-1/8"	1/2"	1-1/2"	5/16"
0940	1/2"	1-1/4"	5/8"	1-1/2"	3/8"
0941	1/2"	1-1/2"	5/8"	1-1/2"	1/2"
0942	1/2"	2"	7/8"	1-1/2"	3/4"

0666

Dovetail Bits

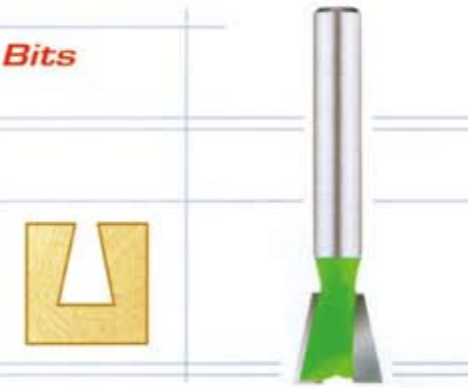

0461

**Slotting Bits
Four Flutes With Bearing**



0511

T-Slot Bit

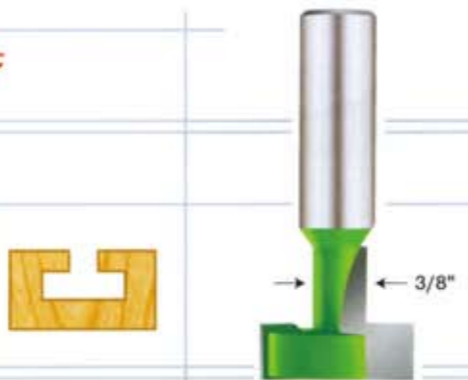

1366

**Rabbeting Bits
With Bearing**

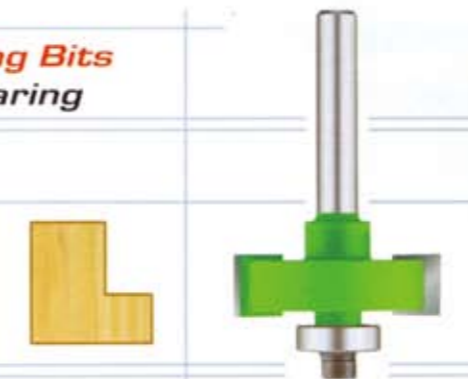

ITEM NO.	SHANK DIA.	CUTTER DIA.	CUTTING LENGTH	SHANK LENGTH	ANGLE
0666	1/4"	1/4"	5/16"	1-1/4"	7°
0667	1/4"	5/16"	3/8"	1-1/4"	8°
0668	1/4"	3/8"	3/8"	1-1/4"	8°
0670	1/4"	1/2"	1/2"	1-1/4"	14°
0669	1/4"	17/32"	1/2"	1-1/4"	14°
0671	1/4"	9/16"	1/2"	1-1/4"	14°
0672	1/4"	3/4"	3/4"	1-1/4"	14°
0691	1/4"	3/8"	3/8"	1-7/8"	8°
0692	1/4"	1/2"	1/2"	1-3/4"	15°
0693	1/4"	1/2"	5/8"	2"	8°
0706	1/2"	11/16"	7/8"	1-7/8"	8°
0707	1/2"	13/16"	1-1/8"	2-1/8"	8°
0711	1/2"	17/32"	1/2"	1-1/2"	14°
0712	1/2"	1/2"	1/2"	1-1/2"	14°
0713	1/2"	5/8"	3/4"	1-1/2"	7°
0714	1/2"	3/4"	1-1/8"	1-1/2"	7°
0715	1/2"	3/4"	3/4"	1-1/2"	14°
0716	1/2"	1"	1-1/8"	1-1/2"	14°

ITEM NO.	SHANK DIA.	CUTTER DIA.	CUTTING LENGTH	SHANK LENGTH	CUTTING DEPTH
0461	1/4"	1-7/8"	1/8"	1-1/4"	1/2"
0462	1/4"	1-7/8"	3/16"	1-1/4"	1/2"
0463	1/4"	1-7/8"	1/4"	1-1/4"	1/2"
0464	1/4"	2"	1/8"	1-1/4"	9/16"
0465	1/4"	2"	5/32"	1-1/4"	9/16"
0466	1/4"	2"	3/16"	1-1/4"	9/16"
0467	1/4"	2"	1/4"	1-1/4"	9/16"
0486	1/2"	1-7/8"	1/8"	1-1/2"	1/2"
0487	1/2"	1-7/8"	3/16"	1-1/2"	1/2"
0488	1/2"	1-7/8"	1/4"	1-1/2"	1/2"
0489	1/2"	2"	1/8"	1-1/2"	9/16"
0490	1/2"	2"	5/32"	1-1/2"	9/16"
0491	1/2"	2"	3/16"	1-1/2"	9/16"
0492	1/2"	2"	1/4"	1-1/2"	9/16"

ITEM NO.	SHANK DIA.	CUTTER DIA.	CUTTING LENGTH	SHANK LENGTH	T-WIDTH
0511	1/2"	1"	7/8"	1-1/2"	3/8"

ITEM NO.	SHANK DIA.	CUTTER DIA.	CUTTING LENGTH	SHANK LENGTH
1366	1/4"	1-1/4"	1/16"	1-1/4"
1367	1/4"	1-1/4"	1/8"	1-1/4"
1368	1/4"	1-1/4"	5/32"	1-1/4"
1369	1/4"	1-1/4"	3/16"	1-1/4"
1370	1/4"	1-1/4"	1/4"	1-1/4"
1371	1/4"	1-1/4"	3/8"	1-1/4"
1372	1/4"	1-1/4"	1/2"	1-1/4"
1411	1/2"	1-1/4"	1/8"	1-1/2"
1412	1/2"	1-1/4"	1/4"	1-1/2"
1413	1/2"	1-1/4"	3/8"	1-1/2"
1414	1/2"	1-1/4"	1/2"	1-1/2"
1415	1/2"	1-1/4"	5/8"	1-1/2"
1416	1/2"	1-1/4"	3/4"	1-1/2"

1396

Rabbeting Bits With Bearing Set

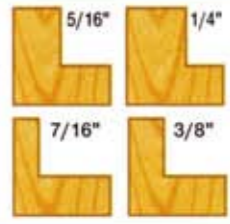

COMPLETE KIT INCLUDES 4 BEARINGS, HEX KEY, WASHER, AND SCREW.

ITEM NO.	SHANK DIA.	CUTTER DIA.	CUTTING LENGTH	SHANK LENGTH
1396	1/4"	1-1/4"	1/2"	1-1/4"
1441	1/2"	1-1/4"	1/2"	1-1/2"



1361

Inlay Bits With Bearing



ITEM NO.	SHANK DIA.	CUTTER DIA.	CUTTING LENGTH	SHANK LENGTH	CUTTING WIDTH
1361	1/2"	1-1/4"	1/2"	1-1/2"	3/16"
1362	1/2"	1-1/4"	3/4"	1-1/2"	3/16"

1261

Core Box Bits



ITEM NO.	SHANK DIA.	CUTTER DIA.	CUTTING LENGTH	SHANK LENGTH	RADIUS
1261	1/4"	1/4"	1/4"	1-1/4"	1/8"
1262	1/4"	3/8"	1/4"	1-1/4"	3/16"
1263	1/4"	1/2"	11/32"	1-1/4"	1/4"
1264	1/4"	5/8"	3/8"	1-1/4"	5/16"
1265	1/4"	3/4"	15/32"	1-1/4"	3/8"
1291	1/2"	3/4"	5/8"	1-1/2"	3/8"
1292	1/2"	1"	5/8"	1-1/2"	1/2"
1293	1/2"	1-1/2"	1"	1-1/2"	3/4"

1276

Roundnose Bits



ITEM NO.	SHANK DIA.	CUTTER DIA.	CUTTING LENGTH	SHANK LENGTH	RADIUS
1276	1/4"	1/4"	3/8"	1-1/4"	1/8"
1277	1/4"	3/8"	7/16"	1-1/4"	3/16"
1278	1/4"	1/2"	9/16"	1-1/4"	1/4"
1305	1/2"	5/8"	11/16"	1-1/2"	5/16"
1306	1/2"	3/4"	13/16"	1-1/2"	3/8"
1307	1/2"	1"	1"	1-1/2"	1/2"

1321

Plunging Ball Bits



ROUND BOTTOM FINISH



ITEM NO.	SHANK DIA.	CUTTER DIA.	CUTTING LENGTH	SHANK LENGTH	RADIUS
1321	1/4"	1/2"	7/16"	1-1/4"	1/4"
1322	1/4"	3/4"	5/8"	1-1/4"	3/8"
1336	1/2"	1/2"	7/16"	1-1/2"	1/4"
1337	1/2"	5/8"	1/2"	1-1/2"	5/16"
1338	1/2"	3/4"	5/8"	1-1/2"	3/8"
1339	1/2"	1"	15/16"	1-1/2"	1/2"
1340	1/2"	1-1/4"	1-1/8"	1-1/2"	5/8"

1161

Roman Ogee Bits With Bearing

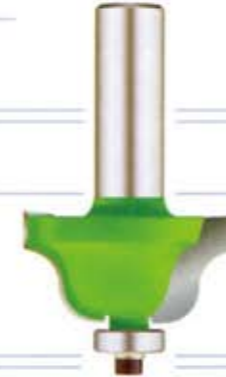

ITEM NO.	SHANK DIA.	CUTTER DIA.	CUTTING LENGTH	SHANK LENGTH	RADIUS
1161	1/4"	1-1/8"	1/2"	1-1/4"	5/32"
1162	1/4"	1-1/2"	3/4"	1-1/4"	1/4"
1191	1/2"	1-1/8"	1/2"	1-1/2"	5/32"
1192	1/2"	1-1/2"	3/4"	1-1/2"	1/4"

1186

Stepped Ogee Bit With Bearing

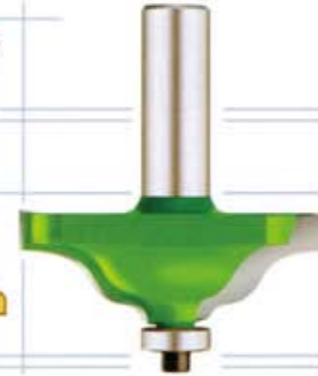

ITEM NO.	SHANK DIA.	CUTTER DIA.	CUTTING LENGTH	SHANK LENGTH	CUTTING WIDTH
1186	1/2"	2-1/4"	3/4"	1-1/2"	13/16"

0736

Ogee Plunge Bits



→d←

ITEM NO.	SHANK DIA.	CUTTER DIA.	CUTTING LENGTH	SHANK LENGTH	d
0736	1/4"	3/8"	3/8"	1-1/4"	1/8"
0737	1/4"	1/2"	7/16"	1-1/4"	1/8"
0738	1/4"	15/16"	5/8"	1-1/4"	3/16"
0739	1/4"	1-5/16"	3/4"	1-1/4"	3/16"
0766	1/2"	3/8"	3/8"	1-1/2"	1/8"
0767	1/2"	1/2"	7/16"	1-1/2"	1/8"
0768	1/2"	15/16"	5/8"	1-1/2"	3/16"
0769	1/2"	1-5/16"	3/4"	1-1/2"	3/16"

0756

Plunging Ogee Bits

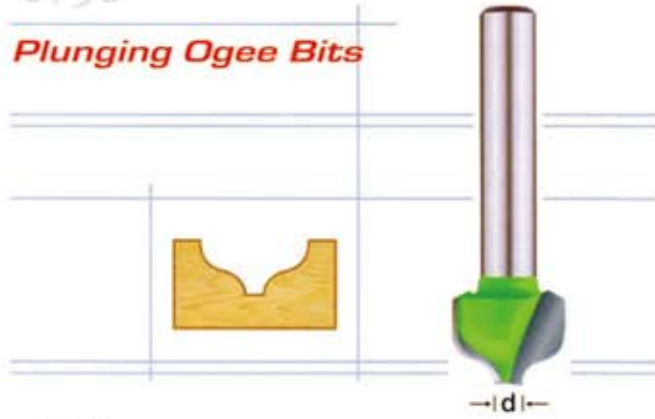

ITEM NO.	SHANK DIA.	CUTTER DIA.	CUTTING LENGTH	SHANK LENGTH	d
0756	1/4"	13/16"	7/16"	1-1/4"	3/16"
0761	1/2"	13/16"	7/16"	1-1/2"	3/16"

2111

Classical Plunging Bits

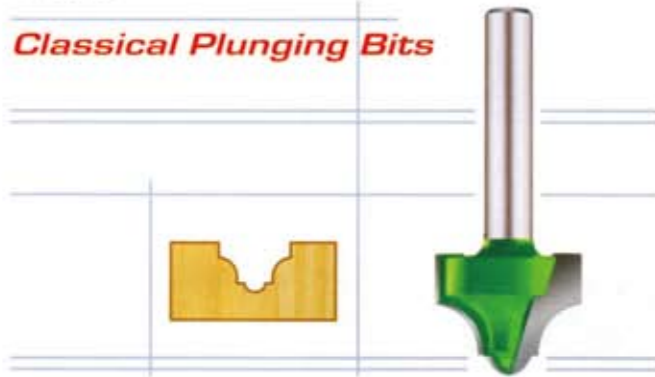

ITEM NO.	SHANK DIA.	CUTTER DIA.	CUTTING LENGTH	SHANK LENGTH	BEAD DIA.
2111	1/4"	1/2"	7/16"	1-1/4"	1/8"
2112	1/4"	3/4"	9/16"	1-1/4"	7/32"
2113	1/4"	1-1/16"	13/16"	1-1/4"	9/32"
2126	1/2"	1/2"	7/16"	1-1/2"	1/8"
2127	1/2"	3/4"	9/16"	1-1/2"	7/32"
2128	1/2"	1-1/16"	13/16"	1-1/2"	9/32"

1961

Beading/Roundover Bits

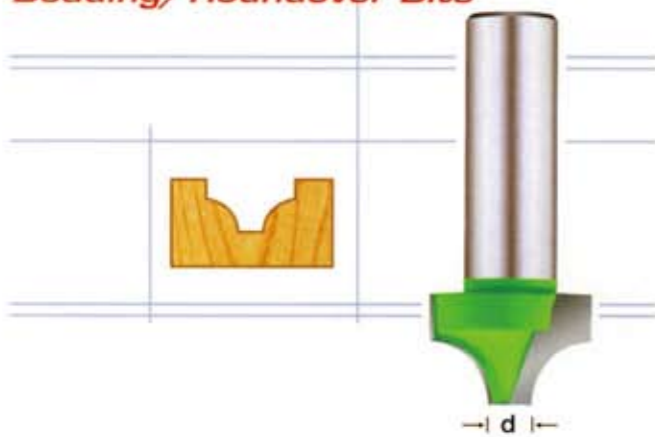

ITEM NO.	SHANK DIA.	CUTTER DIA.	CUTTING LENGTH	SHANK LENGTH	d	RADIUS
1961	1/4"	3/8"	7/16"	1-1/4"	1/8"	1/8"
1962	1/4"	5/8"	1/2"	1-1/4"	1/8"	1/4"
1963	1/4"	13/16"	9/16"	1-1/4"	3/16"	5/16"
1992	1/2"	5/8"	1/2"	1-1/2"	1/8"	1/4"
1993	1/2"	13/16"	9/16"	1-1/2"	3/16"	5/16"
1994	1/2"	1"	5/8"	1-1/2"	1/4"	3/8"

1981

Plunging Roundover Bits

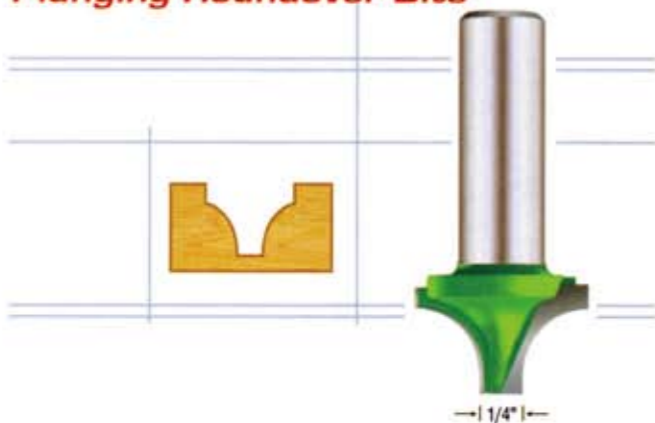

ITEM NO.	SHANK DIA.	CUTTER DIA.	CUTTING LENGTH	SHANK LENGTH	RADIUS
1981	1/4"	1"	5/8"	1-1/4"	3/8"
1986	1/2"	1"	5/8"	1-1/2"	3/8"

2101

Plunging Bead Bits

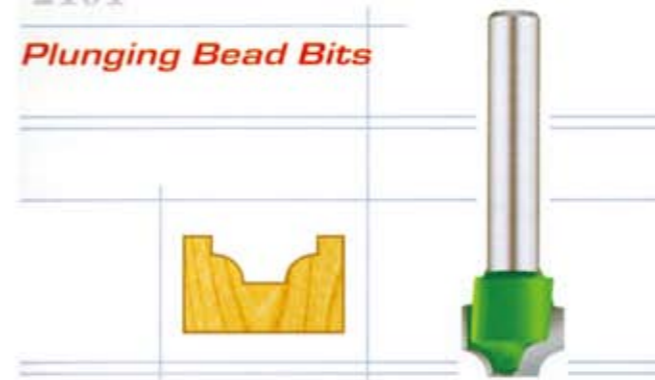

ITEM NO.	SHANK DIA.	CUTTER DIA.	CUTTING LENGTH	SHANK LENGTH	RADIUS
2101	1/4"	1/2"	3/8"	1-1/4"	1/8"
2106	1/2"	1/2"	3/8"	1-1/2"	1/8"

2141

Plunging Quarter Bead Bits

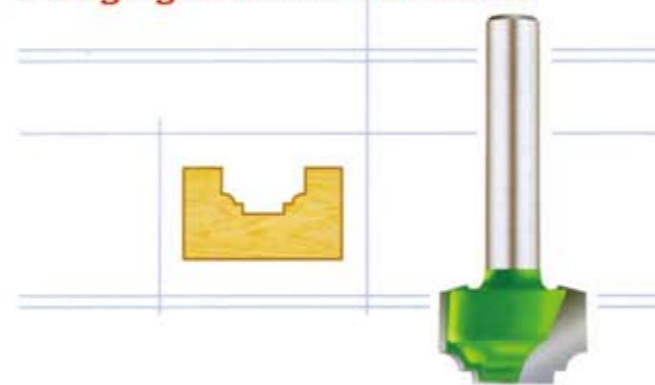

ITEM NO.	SHANK DIA.	CUTTER DIA.	CUTTING LENGTH	SHANK LENGTH	RADIUS
2141	1/4"	11/16"	7/16"	1-1/4"	3/32"
2151	1/2"	11/16"	7/16"	1-1/2"	3/32"

1111

Fingernail (Half Radius)



ITEM NO.	SHANK DIA.	CUTTER DIA.	CUTTING LENGTH	SHANK LENGTH	d
1111	1/4"	3/4"	5/8"	1-1/4"	3/8"
1112	1/4"	3/4"	3/4"	1-1/4"	1/2"
1113	1/4"	7/8"	1"	1-1/4"	3/4"
1141	1/2"	7/8"	9/16"	1-1/2"	3/8"
1142	1/2"	7/8"	3/4"	1-1/2"	1/2"
1143	1/2"	1"	1"	1-1/2"	3/4"
1144	1/2"	1"	1-3/8"	1-1/2"	1"
1145	1/2"	1-1/8"	1-3/4"	1-1/2"	1-1/2"

1051

Bull Nose Bits

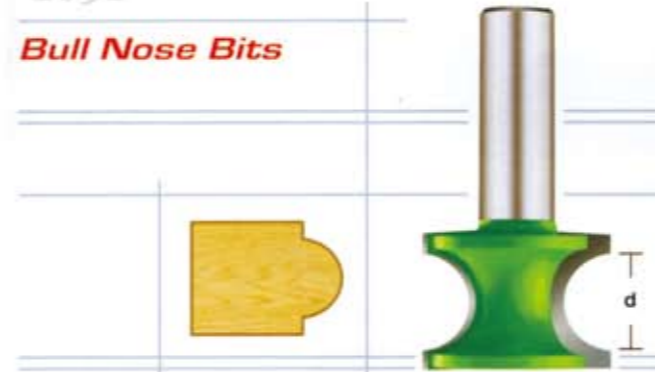

ITEM NO.	SHANK DIA.	CUTTER DIA.	CUTTING LENGTH	SHANK LENGTH	d
1051	1/4"	3/4"	1/2"	1-1/4"	1/4"
1052	1/4"	7/8"	11/16"	1-1/4"	3/8"
1053	1/4"	1"	13/16"	1-1/4"	1/2"
1054	1/4"	1-1/8"	13/16"	1-1/4"	5/8"
1055	1/4"	1-1/4"	1-1/16"	1-1/4"	3/4"
1081	1/2"	7/8"	1/2"	1-1/2"	1/4"
1082	1/2"	1"	5/8"	1-1/2"	3/8"
1083	1/2"	1-1/8"	13/16"	1-1/2"	1/2"
1084	1/2"	1-1/4"	13/16"	1-1/2"	5/8"
1085	1/2"	1-3/8"	1-1/16"	1-1/2"	3/4"
1086	1/2"	1-5/8"	1-3/8"	1-1/2"	1"
1087	1/2"	1-3/4"	1-3/8"	1-1/2"	1-1/8"
1088	1/2"	1-7/8"	1-5/8"	1-1/2"	1-1/4"
1089	1/2"	2"	1-3/4"	1-1/2"	1-3/8"
1090	1/2"	2-1/8"	1-3/4"	1-1/2"	1-1/2"

0961

Internal Radius Bits



ITEM NO.	SHANK DIA.	CUTTER DIA.	CUTTING LENGTH	SHANK LENGTH	RADIUS
0961	1/4"	7/8"	3/8"	1-1/4"	3/16"
0962	1/4"	7/8"	1/2"	1-1/4"	1/4"
0963	1/4"	1"	3/4"	1-1/4"	3/8"
0976	1/2"	7/8"	3/8"	1-1/2"	3/16"
0977	1/2"	7/8"	1/2"	1-1/2"	1/4"
0978	1/2"	7/8"	3/4"	1-1/2"	3/8"
0979	1/2"	1"	1"	1-1/2"	5/8"
0980	1/2"	1-1/8"	1-1/2"	1-1/2"	1-1/8"

0991

**Flute Bits
With Upper & Lower Bearings**



ITEM NO.	SHANK DIA.	CUTTER DIA.	CUTTING LENGTH	SHANK LENGTH	BEARING DIA.
0991	1/4"	7/8"	1/4"	1-1/4"	5/8"
0996	1/2"	1"	3/8"	1-1/2"	5/8"

1711

V-Groove Bits



ITEM NO.	SHANK DIA.	CUTTER DIA.	CUTTING LENGTH	SHANK LENGTH	ANGLE
1711	1/4"	3/8"	7/16"	1-1/4"	90°
1712	1/4"	1/2"	1/2"	1-1/4"	90°
1713	1/4"	3/4"	5/8"	1-1/4"	90°
1714	1/4"	1"	3/4"	1-1/4"	90°
1726	1/4"	1/2"	11mm	1-1/4"	60°
1741	1/2"	3/4"	5/8"	1-1/2"	90°
1742	1/2"	1"	3/4"	1-1/2"	90°
1743	1/2"	1-1/4"	15/16"	1-1/2"	90°

0296

Pattern Bits

**CLASSICAL PLUNGE PATTERN BITS I
- WITH UPPER BEARING**

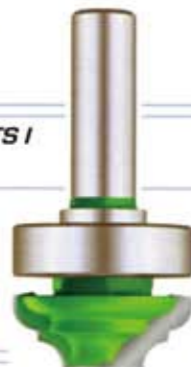

ITEM NO.	SHANK DIA.	CUTTER DIA.	CUTTING LENGTH	RADIUS 1	RADIUS 2
0296	1/4"	7/8"	3/8"	3/32"	3/32"
0301	1/2"	1-3/8"	9/16"	13/64"	13/64"

0306

Pattern Bits

**CLASSICAL PLUNGE PATTERN BITS II
- WITH UPPER BEARING**

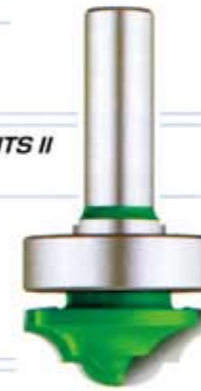

ITEM NO.	SHANK DIA.	CUTTER DIA.	CUTTING LENGTH	RADIUS 1	RADIUS 2
0306	1/4"	7/8"	1/2"	7/32"	5/32"
0311	1/2"	1-3/8"	9/16"	13/32"	1/4"

0316

Pattern Bits

**90° V-GROOVE PATTERN BIT
- WITH UPPER BEARING**

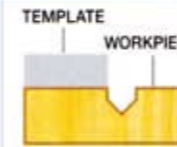

ITEM NO.	SHANK DIA.	CUTTER DIA.	CUTTING LENGTH	ANGLE
0316	1/4"	1/2"	1/2"	90°

0326

Pattern Bits

**DOVETAIL PATTERN BIT
- WITH UPPER BEARING**

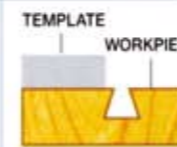

ITEM NO.	SHANK DIA.	CUTTER DIA.	CUTTING LENGTH	ANGLE
0326	1/4"	1/2"	1/2"	14°

0336

Pattern Bits

**CORE BOX PATTERN BIT
- WITH UPPER BEARING**

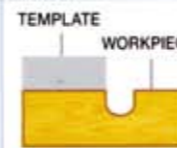

ITEM NO.	SHANK DIA.	CUTTER DIA.	CUTTING LENGTH	RADIUS
0336	1/4"	1/2"	5/8"	1/4"

0276

Pattern Bits**STRAIGHT PATTERN BITS
-WITH UPPER BEARING**

ITEM NO.	SHANK DIA.	CUTTER DIA.	CUTTING LENGTH
0276	1/4"	1/2"	3/4"
0277	1/4"	5/8"	3/4"
0278	1/4"	3/4"	3/4"
0286	1/2"	3/4"	1"
0287	1/2"	1-1/8"	1-3/16"

0351

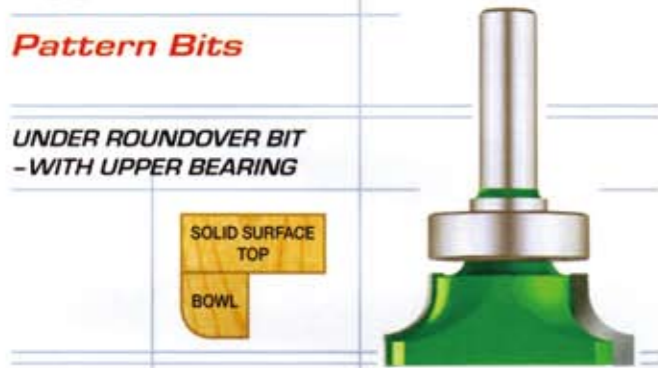
Pattern Bits**UNDER ROUNDOVER BIT
-WITH UPPER BEARING**

ITEM NO.	SHANK DIA.	CUTTER DIA.	CUTTING LENGTH	RADIUS
0351	1/2"	2-1/8"	3/4"	3/8"

0596

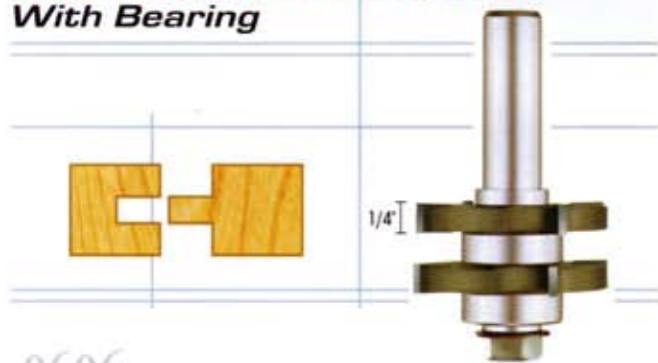
**Tongue & Groove Assembly
With Bearing**

COMPLETE KIT INCLUDES ARBOR, 2 CUTTERS, 2 BEARINGS, AND SHIM SET.

ITEM NO.	SHANK DIA.	CUTTER DIA.	CUTTING LENGTH	CUTTING DEPTH
0596	1/2"	1-3/4"	3/4"	7/16"

0606

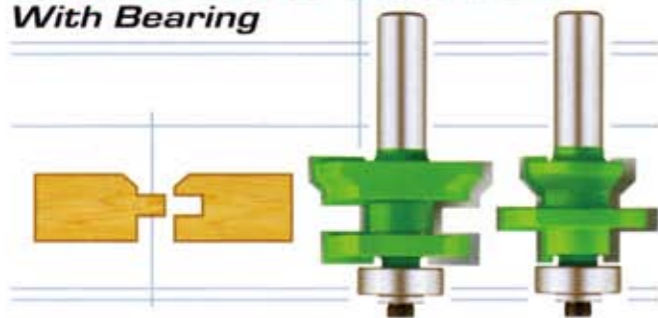
**Tongue & Groove V-match Set
With Bearing**

ITEM NO.	SHANK DIA.	CUTTER DIA.	CUTTING LENGTH	SHANK LENGTH
0606	1/2"	1-7/16"	1"	1-1/2"

0616

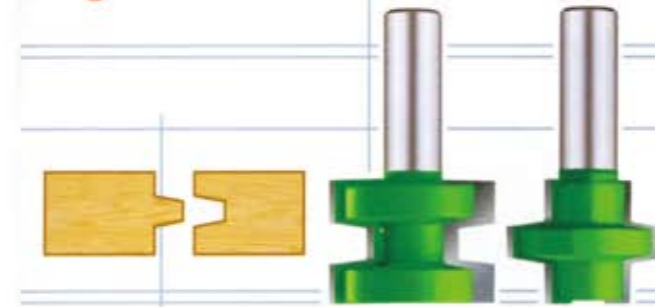
Tongue & Groove Set

ITEM NO.	SHANK DIA.	CUTTER DIA.	CUTTING LENGTH	SHANK LENGTH
0616	1/2"	1-7/16"	1"	1-1/2"

0626

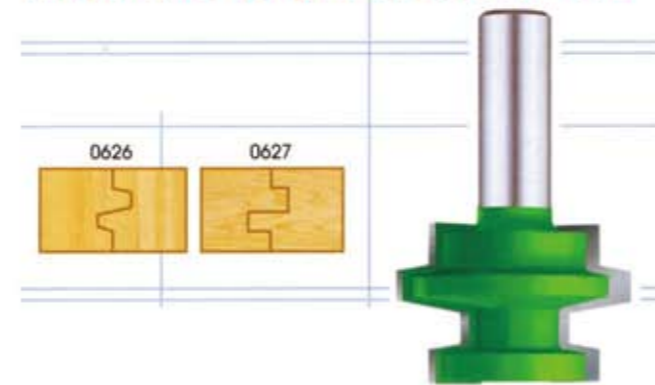
Reversible Tongue & Groove Bits

ITEM NO.	DESCRIPTION	SHANK DIA.	CUTTER DIA.	CUTTING LENGTH	SHANK LENGTH
0626	WEDGE	1/2"	1-5/8"	1"	1-1/2"
0627	STRAIGHT	1/2"	1-5/8"	1"	1-1/2"

0636

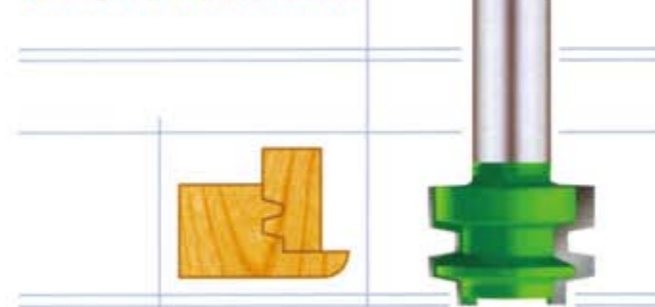
Drawer Lock Bits

ITEM NO.	SHANK DIA.	CUTTER DIA.	CUTTING LENGTH	SHANK LENGTH
0636	1/2"	1-1/16"	3/4"	1-1/2"
0637	1/2"	2"	1/2"	1-1/2"

0641

Glue Joint Bits

ITEM NO.	SHANK DIA.	CUTTER DIA.	CUTTING LENGTH	SHANK LENGTH
0641	1/4"	1"	1-3/16"	1-1/4"
0646	1/2"	1-1/8"	1-1/4"	1-1/2"

0651

**Adjustable Finger Joint Bit
With Bearing**

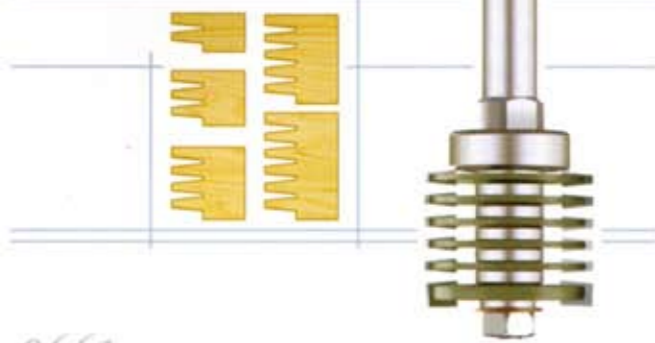

ITEM NO.	SHANK DIA.	CUTTER DIA.	CUTTING LENGTH
0651	1/2"	1-9/16"	1-1/4"

0661

**Finger Joint Bit
With Bearing**

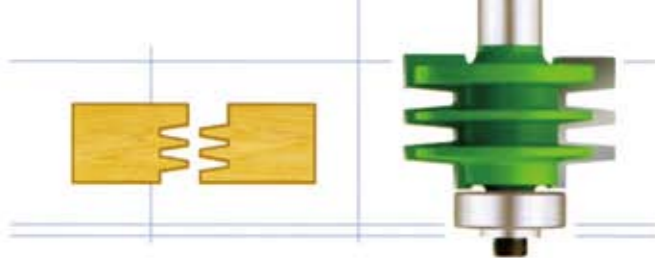

ITEM NO.	SHANK DIA.	CUTTER DIA.	CUTTING LENGTH	SHANK LENGTH
0661	1/2"	1-5/8"	1"	1-1/2"

1006

Finger Pull Bits

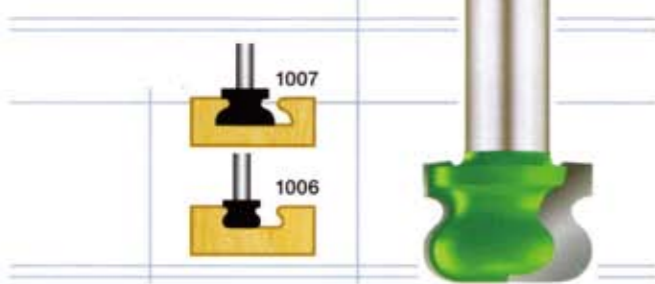

ITEM NO.	SHANK DIA.	CUTTER DIA.	CUTTING LENGTH	SHANK LENGTH
1006	1/2"	1"	3/4"	1-1/2"
1007	1/2"	1-3/8"	3/4"	1-1/2"

1011

**Multiple Beading Bit
With Two Bearings**

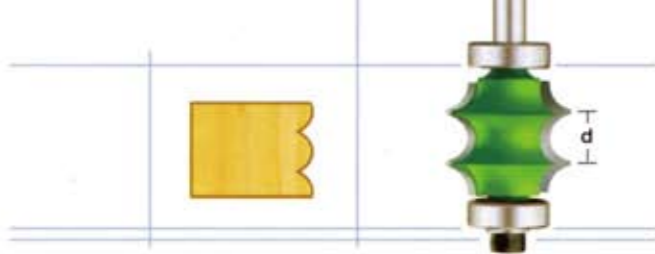

ITEM NO.	SHANK DIA.	CUTTER DIA.	CUTTING LENGTH	SHANK LENGTH	d
1011	1/4"	15/16"	7/8"	1-1/4"	3/8"

2161

**Edge Beading Bits I
With Bearing**

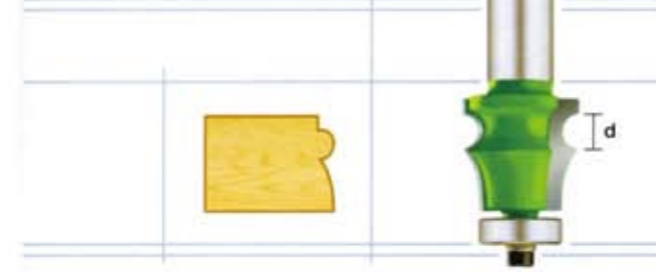

ITEM NO.	SHANK DIA.	CUTTER DIA.	CUTTING LENGTH	SHANK LENGTH	d
2161	1/4"	13/16"	2-1/2"	1-1/4"	1/4"
2171	1/2"	3/4"	3/4"	1-1/2"	1/8"
2172	1/2"	7/8"	13/16"	1-1/2"	1/4"
2173	1/2"	1"	13/16"	1-1/2"	3/8"

2181

**Edge Beading Bits II
With Bearing**



ITEM NO.	SHANK DIA.	CUTTER DIA.	CUTTING LENGTH	SHANK LENGTH	d
2181	1/4"	11/16"	9/16"	1-1/4"	3/16"
2182	1/4"	13/16"	3/4"	1-1/4"	5/16"

2201

**Edge Beading Bits III
With Bearing**



ITEM NO.	SHANK DIA.	CUTTER DIA.	CUTTING LENGTH	SHANK LENGTH	d
2201	1/4"	13/16"	7/8"	1-1/4"	5/16"
2211	1/2"	13/16"	7/8"	1-1/2"	5/16"
2212	1/2"	1"	1"	1-1/2"	1/2"

2221

**Corner Beading Bits
With Bearing**

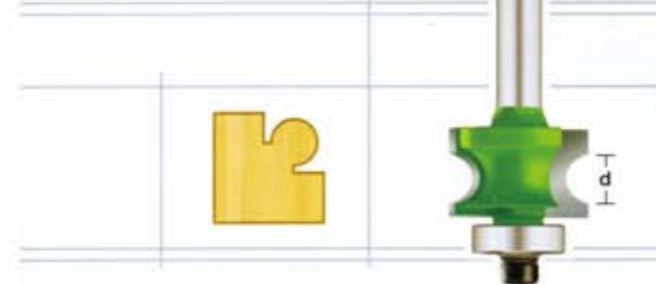

ITEM NO.	SHANK DIA.	CUTTER DIA.	CUTTING LENGTH	SHANK LENGTH	d
2221	1/4"	5/8"	1/4"	1-1/4"	1/8"
2222	1/4"	11/16"	5/16"	1-1/4"	3/16"
2223	1/4"	3/4"	1/2"	1-1/4"	1/4"
2241	1/2"	1"	5/8"	1-1/2"	3/8"
2242	1/2"	1-1/8"	13/16"	1-1/2"	1/2"
2243	1/2"	1-3/16"	7/8"	1-1/2"	5/8"
2244	1/2"	1-5/16"	1-1/16"	1-1/2"	3/4"

1221

Flute & Bead Sets

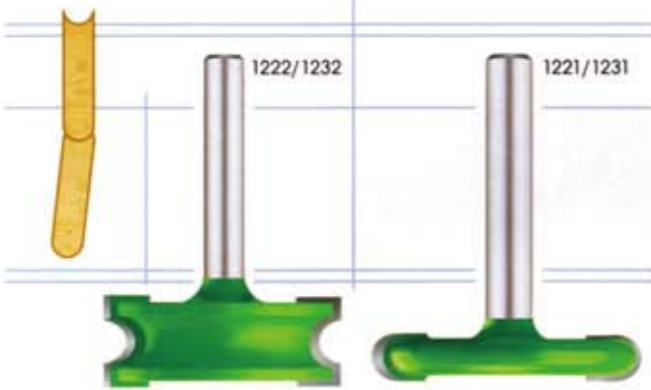

ITEM NO.	DESCRIPTION	SHANK DIA.	CUTTER DIA.	CUTTING LENGTH	SHANK LENGTH
1221	FLUTE	1/4"	1-1/2"	1/4"	1-1/4"
1222	BEAD	1/4"	1-1/2"	1/2"	1-1/4"
1231	FLUTE	1/2"	1-1/2"	1/4"	1-1/2"
1232	BEAD	1/2"	1-1/2"	1/2"	1-1/2"

1021

Picture Frame Bits With Bearing



ITEM NO.	SHANK DIA.	CUTTER DIA.	CUTTING LENGTH	SHANK LENGTH
1021	1/4"	13/16"	1-1/8"	1-1/4"
1022	1/4"	13/16"	1-1/8"	1-1/4"
1023	1/4"	7/8"	1-1/8"	1-1/4"
1036	1/2"	13/16"	1-1/8"	1-1/2"
1037	1/2"	13/16"	1-1/8"	1-1/2"
1038	1/2"	7/8"	1-1/8"	1-1/2"

1886

Door Lip Bits

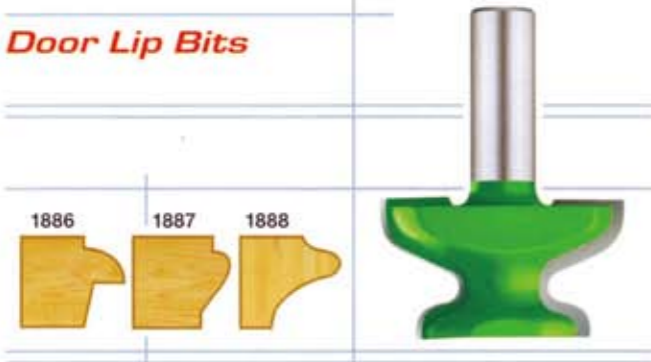

ITEM NO.	SHANK DIA.	CUTTER DIA.	CUTTING LENGTH	SHANK LENGTH
1886	1/2"	1-5/8"	1-1/4"	1-1/2"
1887	1/2"	1-5/16"	1"	1-1/2"
1888	1/2"	1-7/8"	1"	1-1/2"

1836

Corner Lock Miter Bits



ITEM NO.	SHANK DIA.	CUTTER DIA.	CUTTING LENGTH	SHANK LENGTH
1836	1/4"	1-5/8"	11/16"	1-1/4"
1846	1/2"	1-5/8"	11/16"	1-1/2"
1847	1/2"	3"	1"	1-1/2"

0916

Keyhole Bits 1 Flute



ITEM NO.	SHANK DIA.	CUTTER DIA.	CUTTING LENGTH	SHANK LENGTH
0916	1/4"	1/2"	1/2"	1-1/4"
0917	1/4"	3/8"	7/16"	1-1/4"

0926

Dish Cutter Bits

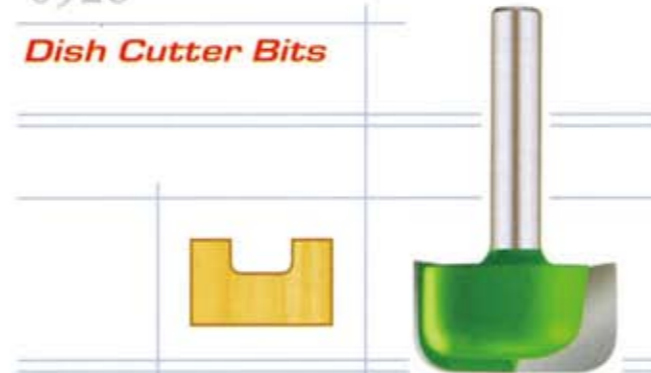

ITEM NO.	SHANK DIA.	CUTTER DIA.	CUTTING LENGTH	SHANK LENGTH	RADIUS
0926	1/4"	1"	1/2"	1-1/4"	3/16"
0931	1/2"	1-1/4"	1/2"	1-1/2"	3/16"

1241

Panel Pilot Bits 1 Flute

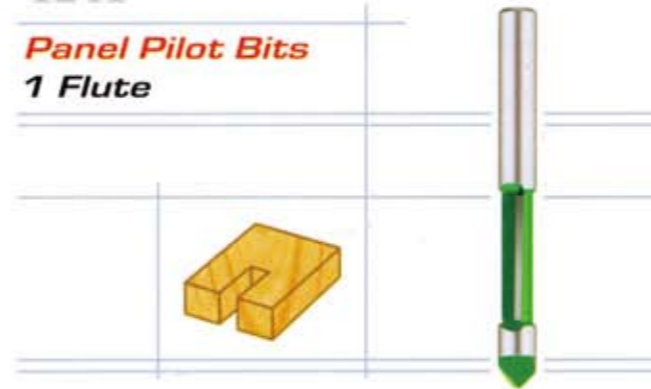

ITEM NO.	SHANK DIA.	CUTTER DIA.	CUTTING LENGTH	SHANK LENGTH
1241	1/4"	1/4"	3/4"	1-1/4"
1242	1/4"	3/8"	3/4"	1-1/4"
1251	1/2"	1/2"	1-1/8"	1-1/2"
1252	1/2"	1/2"	1-1/8"	1-1/2"

1461

Roman Ogee / Round Nose Bit With Bearing

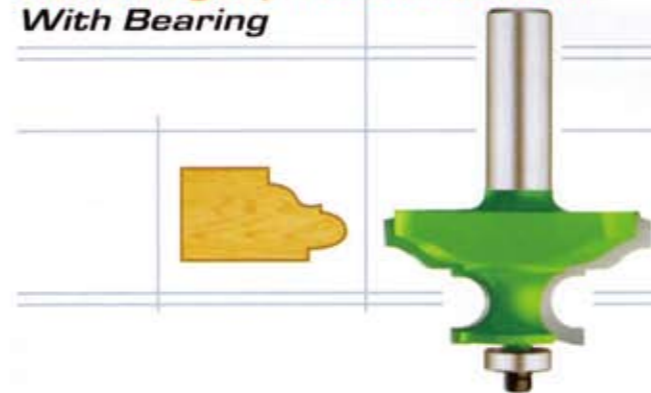

ITEM NO.	SHANK DIA.	CUTTER DIA.	CUTTING LENGTH	SHANK LENGTH	CUTTING WIDTH
1461	1/2"	2"	7/8"	1-1/2"	3/4"

1476

**Double Cove And Bead Bit
With Bearing**



ITEM NO.	SHANK DIA.	CUTTER DIA.	CUTTING LENGTH	SHANK LENGTH	CUTTING WIDTH
1476	1/2"	2"	3/4"	1-1/2"	3/4"

1491

**Ogee Bit
With Bearing**



ITEM NO.	SHANK DIA.	CUTTER DIA.	CUTTING LENGTH	SHANK LENGTH	CUTTING WIDTH
1491	1/2"	2"	1"	1-1/2"	3/4"

1756

**Classical Cove & Bead Bit
With Bearing**

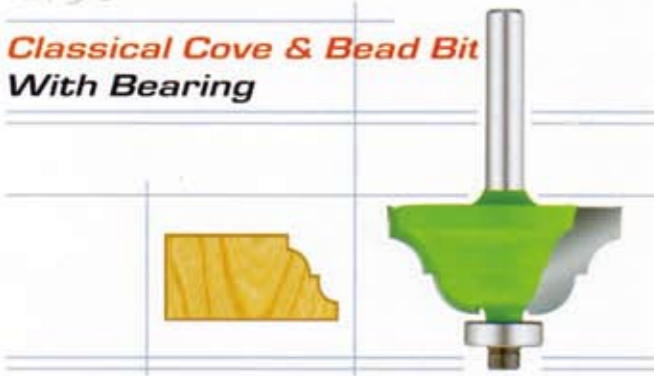

ITEM NO.	SHANK DIA.	CUTTER DIA.	CUTTING LENGTH	SHANK LENGTH	CUTTING WIDTH
1756	1/4"	1-1/4"	5/8"	1-1/4"	3/8"
1757	1/4"	1-1/2"	3/4"	1-1/4"	1/2"
1771	1/2"	1-1/4"	5/8"	1-1/2"	3/8"
1772	1/2"	1-1/2"	3/4"	1-1/2"	1/2"

1806

**Classical Ogee Bits
With Bearing**



ITEM NO.	SHANK DIA.	CUTTER DIA.	CUTTING LENGTH	SHANK LENGTH	CUTTING WIDTH
1806	1/4"	1-1/8"	1/2"	1-1/4"	5/16"
1807	1/4"	1-3/8"	11/16"	1-1/4"	7/16"
1820	1/2"	1-1/8"	1/2"	1-1/2"	5/16"
1821	1/2"	1-3/8"	11/16"	1-1/2"	7/16"

1856

**Classical Roman Ogee Bits
With Bearing**



ITEM NO.	SHANK DIA.	CUTTER DIA.	CUTTING LENGTH	SHANK LENGTH	CUTTING WIDTH
1856	1/4"	1-1/4"	9/16"	1-1/4"	3/8"
1857	1/4"	1-3/8"	5/8"	1-1/4"	7/16"
1871	1/2"	1-1/4"	9/16"	1-1/2"	3/8"
1872	1/2"	1-3/8"	5/8"	1-1/2"	7/16"

1906

**Classical Wave Bits
With Bearing**

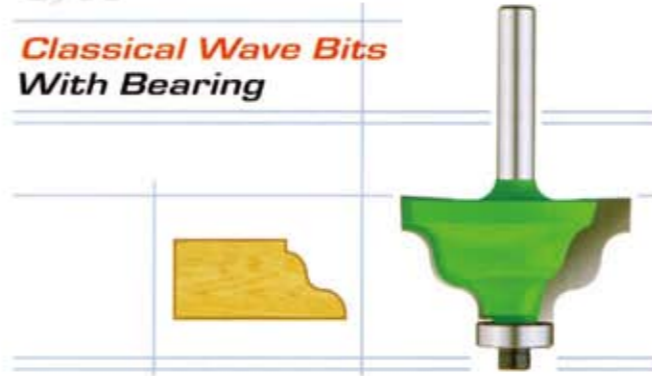

ITEM NO.	SHANK DIA.	CUTTER DIA.	CUTTING LENGTH	SHANK LENGTH	CUTTING WIDTH
1906	1/4"	1-1/2"	3/4"	1-1/4"	1/2"
1921	1/2"	1-1/2"	3/4"	1-1/2"	1/2"

1796

**Classical Bold Bit
With Bearing**



ITEM NO.	SHANK DIA.	CUTTER DIA.	CUTTING LENGTH	SHANK LENGTH	CUTTING WIDTH
1796	1/2"	1-1/2"	1-1/8"	1-1/2"	1/2"

1946

Classical Palace Bits

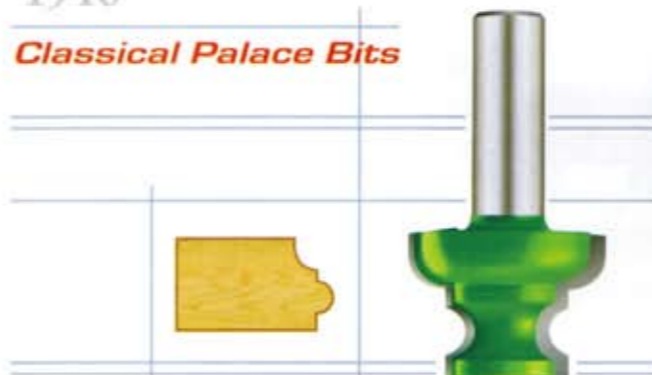

ITEM NO.	SHANK DIA.	CUTTER DIA.	CUTTING LENGTH	SHANK LENGTH	d.
1946	1/2"	1-1/8"	3/4"	1-1/2"	1/4"
1947	1/2"	1-3/8"	1"	1-1/2"	5/16"
1948	1/2"	1-5/8"	1-5/16"	1-1/2"	3/8"

2266

Face Moulding Bits With Bearing



ITEM NO.	SHANK DIA.	CUTTER DIA.	CUTTING LENGTH	SHANK LENGTH
2266	1/2"	1-1/16"	1-3/4"	1-1/2"
2276	1/2"	15/16"	1-7/16"	1-1/2"
2286	1/2"	15/16"	1-3/8"	1-1/2"

2326

Crown Moulding Bits I

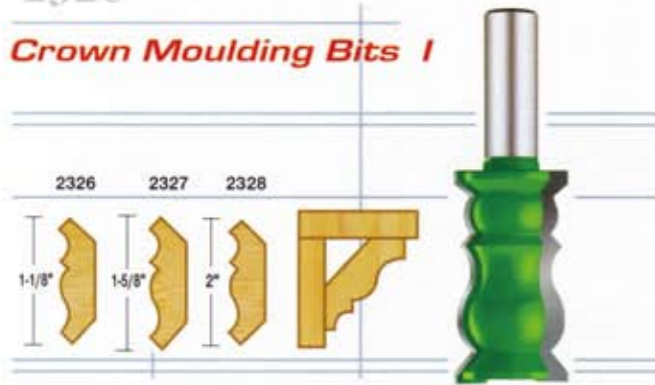

ITEM NO.	SHANK DIA.	CUTTER DIA.	CUTTING LENGTH	SHANK LENGTH
2326	1/2"	1-1/8"	1-1/2"	1-1/2"
2327	1/2"	1-1/8"	1-7/8"	1-1/2"
2328	1/2"	1-3/16"	2-1/4"	1-1/2"

2341

Crown Moulding Bits II

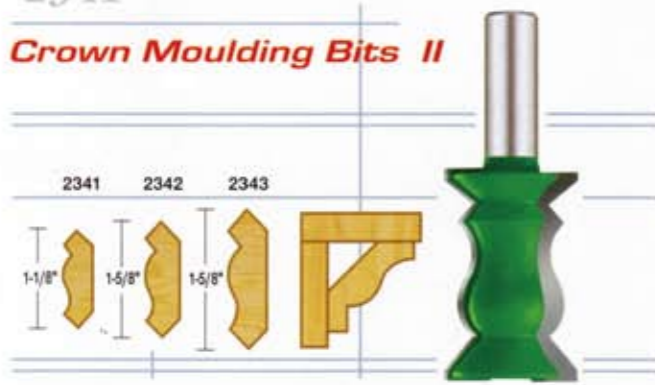

ITEM NO.	SHANK DIA.	CUTTER DIA.	CUTTING LENGTH	SHANK LENGTH
2341	1/2"	1-1/8"	1-1/2"	1-1/2"
2342	1/2"	1-1/8"	1-7/8"	1-1/2"
2343	1/2"	1-3/16"	2-1/4"	1-1/2"

2401

Cove Moulding Bits

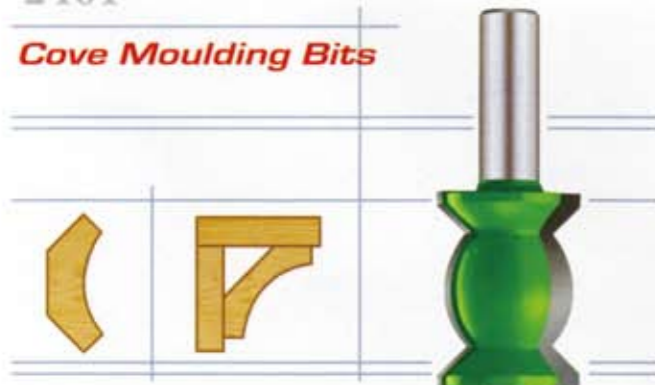

ITEM NO.	SHANK DIA.	CUTTER DIA.	CUTTING LENGTH	SHANK LENGTH	RADIUS
2401	1/2"	7/8"	1-1/2"	1-1/2"	1/2"
2402	1/2"	1"	1-5/8"	1-1/2"	3/4"
2403	1/2"	1-1/8"	1-7/8"	1-1/2"	1-3/16"
2404	1/2"	1-1/8"	2-1/4"	1-1/2"	1-7/8"

2441

Multiform Bit I With Bearing

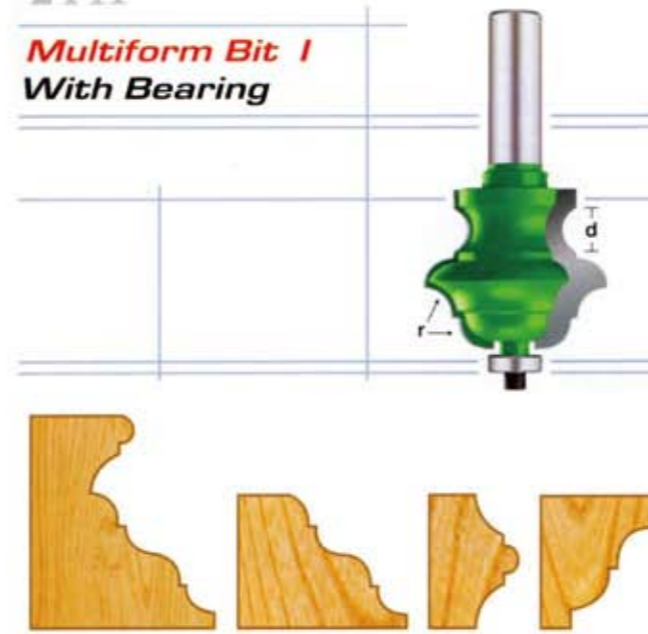

ITEM NO.	SHANK DIA.	CUTTER DIA.	CUTTING LENGTH	SHANK LENGTH	r	d
2441	1/2"	2-3/16"	1-15/16"	1-1/2"	3/8"	7/32"

2442

Multiform Bit II With Bearing

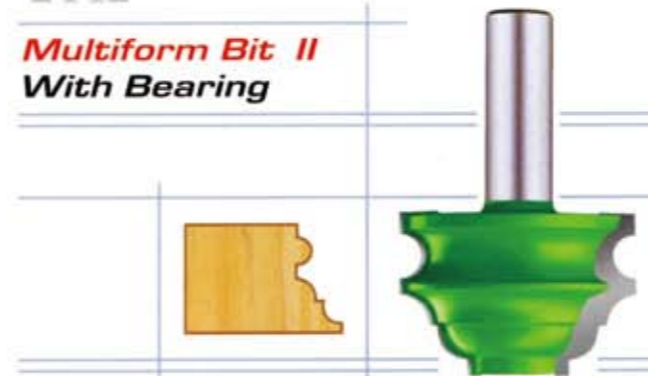

ITEM NO.	SHANK DIA.	CUTTER DIA.	CUTTING LENGTH	SHANK LENGTH	CUTTING WIDTH
2442	1/2"	1-3/4"	1-3/16"	1-1/2"	1/2"

2801

Hinge Boring Bits With Centering Pointed Toe

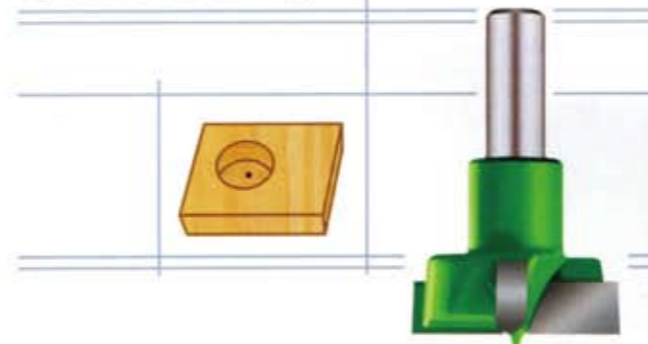

ITEM NO.	SHANK DIA.	CUTTER DIA.	CUTTING LENGTH	OVERALL LENGTH
2801	10mm	25mm	1/2"	57mm
2802	10mm	30mm	1/2"	57mm
2803	10mm	35mm	1/2"	57mm
2804	10mm	40mm	1/2"	57mm
2805	10mm	45mm	1/2"	57mm

2471

Raised Panel Bits With Bearing

2491/2492



2471/2472



2481/2482



2501/2502



2511/2512

• 5° FACE CUT

ITEM NO.	SHANK DIA.	CUTTER DIA.	CUTTING LENGTH	SHANK LENGTH	CUTTING WIDTH
2471	1/2"	2-5/8"	1/2"	1-1/2"	1-1/16"
2472	1/2"	3-1/2"	9/16"	1-1/2"	1-1/2"

• 15° FACE CUT

ITEM NO.	SHANK DIA.	CUTTER DIA.	CUTTING LENGTH	SHANK LENGTH	CUTTING WIDTH
2481	1/2"	2-5/8"	7/16"	1-1/2"	1-1/16"
2482	1/2"	3-1/2"	9/16"	1-1/2"	1-1/2"

• OGEE

ITEM NO.	SHANK DIA.	CUTTER DIA.	CUTTING LENGTH	SHANK LENGTH	CUTTING WIDTH
2491	1/2"	2-5/8"	1/2"	1-1/2"	1-1/16"
2492	1/2"	3-1/2"	9/16"	1-1/2"	1-1/2"

• 12° FACE AND QUARTER ROUND

ITEM NO.	SHANK DIA.	CUTTER DIA.	CUTTING LENGTH	SHANK LENGTH	CUTTING WIDTH
2501	1/2"	2-5/8"	7/16"	1-1/2"	1-1/16"
2502	1/2"	3-1/2"	9/16"	1-1/2"	1-1/2"

• CONVEX

ITEM NO.	SHANK DIA.	CUTTER DIA.	CUTTING LENGTH	SHANK LENGTH	CUTTING WIDTH
2511	1/2"	2-5/8"	1/2"	1-1/2"	1-1/16"
2512	1/2"	3-1/2"	9/16"	1-1/2"	1-1/2"

2871

Rosettee Cutters

2879

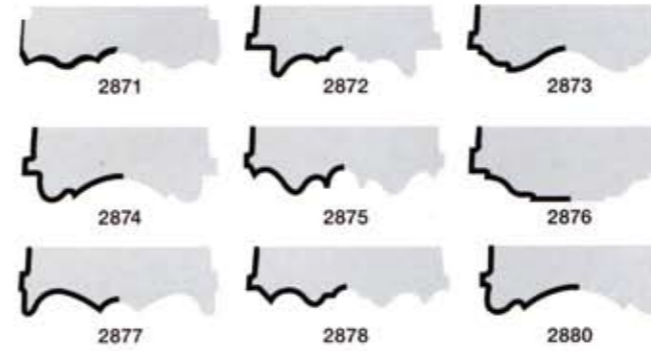

ITEM NO.	SHANK DIA.	CUTTER DIA.	SHANK LENGTH
2871	1/2"	2-1/8"	1-1/2"
2872	1/2"	2-1/8"	1-1/2"
2873	1/2"	2-1/8"	1-1/2"
2874	1/2"	2-1/8"	1-1/2"
2875	1/2"	2-1/8"	1-1/2"
2876	1/2"	2-1/8"	1-1/2"
2877	1/2"	2-1/8"	1-1/2"
2878	1/2"	2-1/8"	1-1/2"
2879	1/2"	2-1/8"	1-1/2"
2880	1/2"	2-1/8"	1-1/2"

2591

One Piece Stile And Rail With Bearing

2591

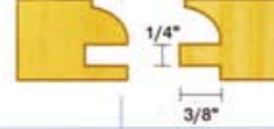

2601

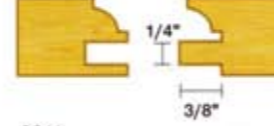

2611

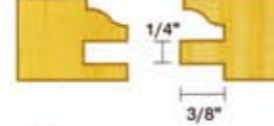

2621

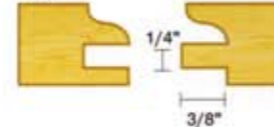

ITEM NO.	DESCRIPTION	SHANK DIA.	CUTTER DIA.	CUTTING LENGTH	SHANK LENGTH
2591	QUARTER ROUND	1/2"	1-5/8"	13/16"	1-1/2"
2601	BEAD	1/2"	1-5/8"	13/16"	1-1/2"
2611	ROMAN OGEE	1/2"	1-5/8"	13/16"	1-1/2"
2621	OGEE	1/2"	1-5/8"	13/16"	1-1/2"

2551

Raised Panel Bits With Under Cutter & Bearing



2551



2556



2561



2566



2571

• 5° FACE CUT

ITEM NO.	SHANK DIA.	CUTTER DIA.	CUTTING LENGTH	SHANK LENGTH	CUTTING WIDTH
2551	1/2"	3-1/8"	1/2"	1-1/2"	1-1/4"

• 15° FACE CUT

ITEM NO.	SHANK DIA.	CUTTER DIA.	CUTTING LENGTH	SHANK LENGTH	CUTTING WIDTH
2556	1/2"	3-1/8"	1/2"	1-1/2"	1-1/4"

• OGEE

ITEM NO.	SHANK DIA.	CUTTER DIA.	CUTTING LENGTH	SHANK LENGTH	CUTTING WIDTH
2561	1/2"	3-1/8"	1/2"	1-1/2"	1-1/4"

• 12° FACE AND QUARTER ROUND

ITEM NO.	SHANK DIA.	CUTTER DIA.	CUTTING LENGTH	SHANK LENGTH	CUTTING WIDTH
2566	1/2"	3-1/8"	1/2"	1-1/2"	1-1/4"

• CONVEX

ITEM NO.	SHANK DIA.	CUTTER DIA.	CUTTING LENGTH	SHANK LENGTH	CUTTING WIDTH
2571	1/2"	3-1/8"	1/2"	1-1/2"	1-1/4"

Reversible Stile And Rail With Bearing

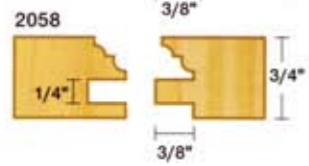
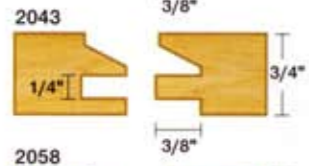
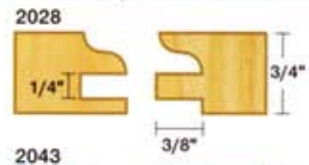
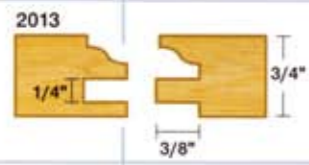

ITEM NO.	DESCRIPTION	SHANK DIA.	CUTTER DIA.	CUTTING LENGTH	SHANK LENGTH
2013	ROMAN OGEE	1/2"	1-5/8"	13/16"	1-1/2"
2028	OGEE	1/2"	1-5/8"	13/16"	1-1/2"
2043	BEVELED	1/2"	1-5/8"	13/16"	1-1/2"
2058	CLASSICAL	1/2"	1-5/8"	13/16"	1-1/2"

2-piece Stile & Rail Sets With Bearing

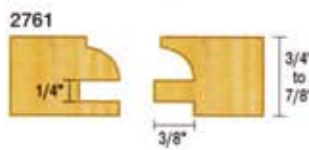
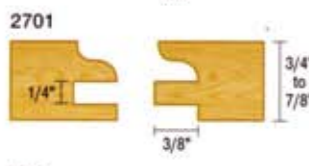
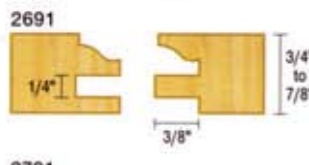
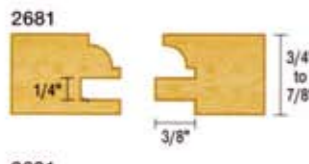
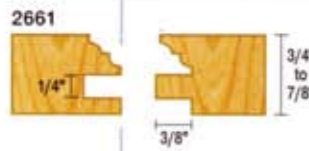

ITEM NO.	DESCRIPTION	SHANK DIA.	CUTTER DIA.	CUTTING LENGTH	SHANK LENGTH
2661	CLASSICAL	1/2"	1-3/4"	1-1/8"	1-1/2"
2671	QUARTER ROUND	1/2"	1-3/4"	1-1/8"	1-1/2"
2681	QUARTER BEAD	1/2"	1-3/4"	1-1/8"	1-1/2"
2691	ROMAN OGEE	1/2"	1-3/4"	1-1/8"	1-1/2"
2701	OGEE	1/2"	1-3/4"	1-1/8"	1-1/2"

Window Sash Sets With Bearing

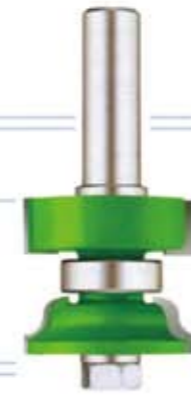

Profile Scriber Multi Set



• BEAD

ITEM NO.	SHANK DIA.	CUTTER DIA.	CUTTING LENGTH	SHANK LENGTH
2741	1/2"	1-1/2"	7/8"	1-1/2"
2742	1/2"	1-1/2"	1-3/8"	1-1/2"

• OGEE

ITEM NO.	SHANK DIA.	CUTTER DIA.	CUTTING LENGTH	SHANK LENGTH
2751	1/2"	1-1/2"	7/8"	1-1/2"
2752	1/2"	1-1/2"	1-3/8"	1-1/2"

LET YOU MAKE TONGUE AND GROOVE AND THREE DIFFERENT TYPES OF STILE & RAIL - ROMAN OGEE, BEVELED, AND CLASSICAL.

SET INCLUDES 3 PROFILE BLOCKS, 2 SLOTTERS, 1 ARBOR, 2 BEARINGS, AND SHIM SET.

ITEM NO.	SHANK DIA.	CUTTER DIA.	RADIUS
2781	1/4"	1-5/8"	4mm & 3.5mm
2782	1/2"	1-5/8"	4mm & 3.5mm

Number Index

Item	Pg.	Item	Pg.	Item	Pg.	Item	Pg.	Item	Pg.	Item	Pg.	Item	Pg.	Item	Pg.	Item	Pg.
0001	02	0196	01	0408	06	0636	16	0823	05	1053	12	1306	09	1714	13	2126	11
0002	02	0197	01	0409	06	0637	16	0824	05	1054	12	1307	09	1726	13	2127	11
0003	02	0198	01	0410	06	0641	16	0851	05	1055	12	1321	10	1741	13	2128	11
0011	01	0199	01	0411	06	0646	16	0852	05	1081	12	1322	10	1742	13	2141	12
0012	01	0200	01	0436	06	0651	17	0866	05	1082	12	1336	10	1743	13	2151	12
0013	01	0201	01	0441	07	0661	17	0867	05	1083	12	1337	10	1756	21	2161	18
0014	01	0202	01	0442	07	0666	08	0881	06	1084	12	1338	10	1757	21	2171	18
0015	01	0226	03	0451	07	0667	08	0891	07	1085	12	1339	10	1771	21	2172	18
0016	01	0227	03	0452	07	0668	08	0892	07	1086	12	1340	10	1772	21	2173	18
0041	01	0228	03	0453	07	0669	08	0893	07	1087	12	1361	09	1796	22	2181	18
0042	01	0241	02	0461	08	0670	08	0894	07	1088	12	1362	09	1806	21	2182	18
0043	01	0242	02	0462	08	0671	08	0895	07	1089	12	1366	08	1807	21	2201	18
0071	01	0243	02	0463	08	0672	08	0896	07	1090	12	1367	08	1820	21	2211	18
0081	02	0244	02	0464	08	0691	08	0897	07	1111	12	1368	08	1821	21	2212	18
0088	02	0256	02	0465	08	0692	08	0916	20	1112	12	1369	08	1836	19	2221	18
0089	02	0257	02	0466	08	0693	08	0917	20	1113	12	1370	08	1846	19	2222	18
0096	01	0258	02	0467	08	0706	08	0926	20	1141	12	1371	08	1847	19	2223	18
0097	01	0259	02	0486	08	0707	08	0931	20	1142	12	1372	08	1856	22	2241	18
0098	01	0260	02	0487	08	0711	08	0936	07	1143	12	1396	09	1857	22	2242	18
0099	01	0276	15	0488	08	0712	08	0937	07	1144	12	1411	08	1871	22	2243	18
0100	01	0277	15	0489	08	0713	08	0938	07	1145	12	1412	08	1872	22	2244	18
0101	01	0278	15	0490	08	0714	08	0939	07	1161	10	1413	08	1886	19	2266	23
0102	01	0286	15	0491	08	0715	08	0940	07	1162	10	1414	08	1887	19	2276	23
0103	01	0287	15	0492	08	0716	08	0941	07	1186	10	1415	08	1888	19	2286	23
0136	03	0296	13	0511	08	0736	10	0942	07	1191	10	1416	08	1906	22	2326	23
0137	03	0301	13	0516	06	0737	10	0961	13	1192	10	1441	09	1921	22	2327	23
0138	03	0306	14	0517	06	0738	10	0962	13	1221	19	1461	20	1946	22	2328	23
0139	03	0311	14	0518	06	0739	10	0963	13	1222	19	1476	21	1947	22	2341	23
0151	02	0316	14	0519	06	0756	11	0976	13	1231	19	1491	21	1948	22	2342	23
0152	02	0326	14	0520	06	0761	11	0977	13	1232	19	1511	03	1961	11	2343	23
0153	02	0336	14	0521	06	0766	10	0978	13	1241	20	1512	03	1962	11	2401	23
0166	02	0351	15	0522	06	0767	10	0979	13	1242	20	1513	03	1963	11	2402	23
0167	02	0356	06	0556	07	0768	10	0980	13	1251	20	1514	03	1981	11	2403	23
0168	02	0357	06	0561	06	0769	10	0991	13	1252	20	1541	03	1986	11	2404	23
0169	02	0358	06	0562	06	0786	05	0996	13	1261	09	1542	03	1992	11	2441	24
0170	02	0359	06	0563	06	0787	05	1006	17	1262	09	1571	03	1993	11	2442	24
0186	01	0360	06	0564	06	0788	05	1007	17	1263	09	1572	03	1994	11	2471	25
0187	01	0361	06	0565	06	0789	05	1011	17	1264	09	1591	03	2013	27	2472	25
0188	01	0362	06	0566	06	0811	05	1021	19	1265	09	1592	03	2028	27	2481	25
0189	01	0401	06	0567	06	0816	05	1022	19	1276	09	1610	04	2043	27	2482	25
0190	01	0402	06	0568	06	0817	05	1023	19	1277	09	1631	04	2058	27	2491	25
0191	01	0403	06	0596	15	0818	05	1036	19	1278	09	1651	04	2101	12	2492	25
0192	01	0404	06	0606	15	0819	05	1037	19	1291	09	1671	04	2106	12	2501	25
0193	01	0405	06	0616	16	0820	05	1038	19	1292	09	1711	13	2111	11	2502	25
0194	01	0406	06	0626	16	0821	05	1051	12	1293	09	1712	13	2112	11	2511	25
0195	01	0407	06	0627	16	0822	05	1052	12	1305	09	1713	13	2113	11	2512	25

INDEX

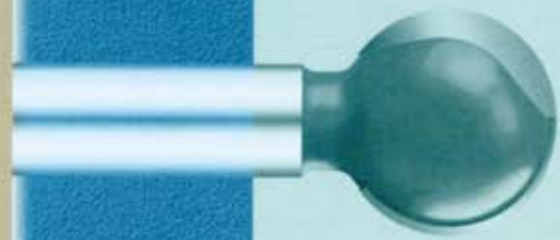

ROUTER BITS

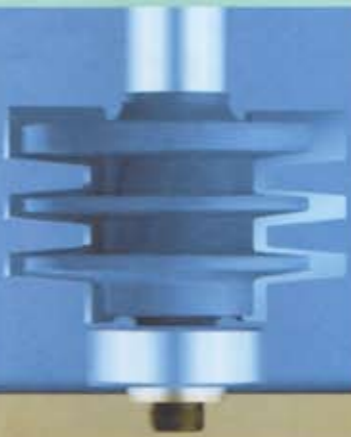

EZ

CUT

ROUTER BITS

I'm your best partner to work with !



EZCUT®