

E Z

C U T

> YOUR BEST PARTNER TO WORK WITH !

Introduction

Sen Yeong Precision Tool Co. is a professional manufacturer of carbide tipped Router Bits and Shaper Cutters. The company was founded in 1965. Over these 34 years, we have continued growing, improving, and accumulating experiences and skills.



In the production processes, we enforce a fine quality assurance system and are accredited by ISO 9002 in 1997. Therefore, durability and stability of our products are guaranteed. We are confident of meeting your quality requests and being a supplier you can rely on.



EZCUT® is our new brand name.

You can recognize us easily.

EZCUT® reveals our insistence on quality and our energetic, creative spirit.

Give us a try, we can be your best partner to work with !

S P M_T M_S

Product and Quality

Varied grades of products are available.

Standard Good quality with competitive prices.

Premium Better Stability & Higher Durability.

Micrograin (Top/Super) Micrograin carbide and better steel make products of Superior Quality.























OUR QUALITY POLICY

EXCELLENT QUALITY * FAST DELIVERY * SATISFIED CUSTOMER

index

| | | | |
|---|---|---|--|
|  | Straight Bit (1, 2, 3) | 4062-4213 1 | |
| | 4214-4231 2 | | |
| | 4001-4022 | | |
| | 4031-4043 | | |
| | 4051-4164 | | |
| | 4341-4394 3 | | |
| | 4091-4103 | | |
| | 4151-4173 | | |
| |  | Flush Trimming Bit (4, 5) | 4291-4297 4 |
| | | 4423-4483 | |
| 4556-4574 | | | |
| 6451-6472 | | | |
| 6131-6136 5 | | | |
| 6201 | | | |
|  | Chamfer Bit (5) | 4601-4641 5 | |
| |  | Roundover Bit (5, 6) | 4831 5 |
| 4841-4888 6 | | | |
|  | Solid Surface Bit (6, 7) | 4891 6 | |
| | 4251-4252 | | |
| | 4261 7 | | |
| | 4271-4275 | | |
| 4281 | | | |
|  | Handrail Bit Set (8) | 4361-4362 8 | |
| | 4371-4373 | | |
|  | Beading Bit (8) | 4781-4826 8 | |
| | 4851 | | |
|  | Cove Bit (9) | 5051-5104 9 | |
| |  | Dovetail Bit (9) | 5551 9 |
| 5561-5609 | | | |
|  | Rabbeting Bit (10) | 5201-5254 10 | |
| | 5951-5986 | | |
| | 6026-6029 | | |

| | | | |
|---|---|---|---|
|  | Core Box Bit (11, 12) | 5681 11 | |
| | 5696-5741 | | |
| | 5763-5787 | | |
| | 5861-5885 12 | | |
|  | Roman Ogee Bit (12) | 5121-5128 12 | |
| | 5141 | | |
|  | Plunge Bit (12, 13, 14) | 4736-4771 12 | |
| | 4301-4302 13 | | |
| | 4331-4312 | | |
| | 4901-4933 | | |
| | 4946-4978 14 | | |
| | 4991-5011 | | |
| | 5021-5042 | | |
| | 5161-5181 | | |
| |  | Bull Nose Bit (15) | 4701-4715 15 |
| | | 4661-4678 | |
|  | V-Groove Bit (15, 16) | 5621-5678 15 | |
| | 5611 16 | | |
|  | Tongue & Groove (16) | 5816-5821 16 | |
| | 5831 | | |
| |  | Lock Miter Bit (17) | 5911-5912 17 |
| 6071-6072 | | | |
| 6081-6091 | | | |
| 6101-6122 | | | |
|  | Finger Joint Bit (18) | 5801-5806 18 | |
| | 5991 | | |
| | 4501-4508 | | |
| | 4521-4532 | | |
|  | Edge Beading Bit (19) | 4541-4547 19 | |
| | 4561-4584 | | |
| |  | Flute & Bead Set (19) | 5891-2902 19 |

| | | |
|---|---|--|
|  | Keyhole Bit (19, 20) | 6001 19 |
| | 6011-6012 20 | |
|  | Panel Pilot Bit (20) | 6041-6052 20 |
| |  | Moulding Bit (20, 21, 22, 23, 24) |
| 5271-5282 | | |
| 5331-5342 21 | | |
| 5356-5361 | | |
| 5381-5412 | | |
| 5371 | | |
| 5401-5403 22 | | |
| 5421-5423 | | |
| 5431-5433 | | |
| 5446-5448 | | |
| 5451-5454 23 | | |
| 5461 | | |
| 5501 | | |
| 5471-5502 24 | | |
| 5511 | | |
| 5521 | | |
|  | Hinge Boring Bit (24) | 6261-6265 24 |
| |  | Raised Panel Bit (25) |
| 6401-6421 | | |
|  | | Rosettee Cutter (26) |
| |  | Stile & Rail (26, 27, 28) |
| 6481-6484 27 | | |
| 6291-6294 | | |
| 6301-6305 28 | | |
| 6241 | | |
|  | Window Sash Set (29) | 6321-6332 29 |
| |  | Radius Bit (29) |
|  | | Finger Pull Bit & Door Lip Bit (29) |
| | 6231-6233 | |

Straight Bits
2 flutes



| ITEM NO. | SHANK DIA. | CUTTER DIA. | CUTTING LENGTH | OVERALL LENGTH |
|----------|------------|-------------|----------------|----------------|
| 4062 | 6 | 6 | 19 | 55 |
| 4064 | 6 | 7 | 19 | 51 |
| 4066 | 6 | 8 | 19 | 51 |
| 4067 | 6 | 8 | 25 | 57 |
| 4068 | 6 | 9 | 19 | 51 |
| 4069 | 6 | 10 | 19 | 51 |
| 4070 | 6 | 10 | 25 | 57 |
| 4072 | 6 | 11 | 19 | 51 |
| 4073 | 6 | 12 | 19 | 51 |
| 4074 | 6 | 12 | 25 | 57 |
| 4076 | 6 | 14 | 19 | 51 |
| 4078 | 6 | 15 | 19 | 51 |
| 4079 | 6 | 16 | 19 | 51 |
| 4081 | 6 | 18 | 19 | 51 |
| 4082 | 6 | 19 | 19 | 51 |
| 4083 | 6 | 20 | 19 | 51 |
| 4084 | 6 | 22 | 19 | 51 |
| 4085 | 6 | 25 | 19 | 51 |
| 4111 | 8 | 6 | 19 | 57 |
| 4113 | 8 | 7 | 19 | 57 |
| 4114 | 8 | 8 | 19 | 57 |
| 4115 | 8 | 8 | 25 | 63 |
| 4116 | 8 | 10 | 19 | 51 |
| 4117 | 8 | 10 | 25 | 57 |
| 4118 | 8 | 10 | 30 | 62 |
| 4119 | 8 | 11 | 19 | 51 |
| 4120 | 8 | 12 | 19 | 51 |
| 4121 | 8 | 12 | 25 | 57 |
| 4122 | 8 | 12 | 30 | 62 |
| 4123 | 8 | 14 | 19 | 51 |
| 4124 | 8 | 14 | 25 | 57 |
| 4125 | 8 | 15 | 25 | 57 |
| 4126 | 8 | 16 | 19 | 51 |
| 4127 | 8 | 16 | 25 | 57 |
| 4129 | 8 | 16 | 30 | 62 |
| 4130 | 8 | 18 | 19 | 51 |
| 4131 | 8 | 19 | 19 | 51 |
| 4132 | 8 | 19 | 30 | 62 |
| 4133 | 8 | 20 | 19 | 51 |
| 4134 | 8 | 22 | 19 | 51 |
| 4135 | 8 | 24 | 19 | 51 |
| 4136 | 8 | 25 | 19 | 51 |
| 4137 | 8 | 25 | 30 | 62 |
| 4191 | 12 | 6 | 19 | 63 |
| 4193 | 12 | 8 | 19 | 63 |
| 4194 | 12 | 8 | 25 | 70 |
| 4195 | 12 | 10 | 19 | 63 |
| 4196 | 12 | 10 | 25 | 70 |
| 4197 | 12 | 10 | 32 | 73 |
| 4198 | 12 | 12 | 25 | 70 |
| 4199 | 12 | 12 | 32 | 73 |
| 4200 | 12 | 12 | 38 | 79 |
| 4201 | 12 | 12 | 50 | 98 |
| 4202 | 12 | 14 | 25 | 67 |
| 4203 | 12 | 14 | 32 | 73 |
| 4204 | 12 | 15 | 19 | 61 |
| 4205 | 12 | 16 | 25 | 67 |
| 4207 | 12 | 16 | 32 | 73 |
| 4208 | 12 | 16 | 51 | 93 |
| 4209 | 12 | 16 | 19 | 61 |
| 4210 | 12 | 17 | 32 | 73 |
| 4211 | 12 | 18 | 19 | 60 |
| 4212 | 12 | 18 | 51 | 93 |
| 4213 | 12 | 18 | 32 | 73 |

Straight Bits
1 flute



Inserted Solid Carbide Straight Bits
1 flute



Shear Cut Straight Bits
2 Flutes



Cutting edge is angled.

| | | | | |
|------|----|----|----|-----|
| 4214 | 12 | 19 | 25 | 67 |
| 4215 | 12 | 20 | 51 | 100 |
| 4216 | 12 | 20 | 25 | 67 |
| 4217 | 12 | 20 | 32 | 73 |
| 4218 | 12 | 22 | 25 | 67 |
| 4219 | 12 | 22 | 32 | 73 |
| 4221 | 12 | 24 | 32 | 73 |
| 4222 | 12 | 24 | 19 | 60 |
| 4223 | 12 | 25 | 25 | 70 |
| 4224 | 12 | 25 | 32 | 73 |
| 4226 | 12 | 26 | 25 | 70 |
| 4227 | 12 | 30 | 25 | 70 |
| 4228 | 12 | 35 | 25 | 70 |
| 4229 | 12 | 35 | 32 | 73 |
| 4230 | 12 | 40 | 25 | 70 |
| 4231 | 12 | 40 | 32 | 73 |

| ITEM NO. | SHANK DIA. | CUTTER DIA. | CUTTING LENGTH | OVERALL LENGTH |
|----------|------------|-------------|----------------|----------------|
| 4001 | 6 | 3 | 11 | 40 |
| 4002 | 6 | 4 | 11 | 40 |
| 4003 | 6 | 5 | 11 | 40 |
| 4011 | 8 | 3 | 11 | 48 |
| 4012 | 8 | 4 | 11 | 48 |
| 4013 | 8 | 5 | 15 | 52 |
| 4021 | 12 | 4 | 11 | 51 |
| 4022 | 12 | 5 | 15 | 51 |

| ITEM NO. | SHANK DIA. | CUTTER DIA. | CUTTING LENGTH | OVERALL LENGTH |
|----------|------------|-------------|----------------|----------------|
| 4031 | 6 | 3 | 10 | 44 |
| 4032 | 6 | 4 | 10 | 61 |
| 4033 | 6 | 5 | 10 | 61 |
| 4041 | 8 | 3 | 11 | 44 |
| 4042 | 8 | 4 | 11 | 44 |
| 4043 | 8 | 5 | 11 | 44 |

| ITEM NO. | SHANK DIA. | CUTTER DIA. | CUTTING LENGTH | OVERALL LENGTH |
|----------|------------|-------------|----------------|----------------|
| 4051 | 6 | 6 | 19 | 51 |
| 4052 | 6 | 10 | 19 | 51 |
| 4053 | 6 | 12 | 19 | 51 |
| 4141 | 8 | 6 | 19 | 51 |
| 4142 | 8 | 10 | 19 | 51 |
| 4143 | 8 | 12 | 19 | 51 |
| 4161 | 12 | 6 | 19 | 70 |
| 4162 | 12 | 10 | 25 | 70 |
| 4163 | 12 | 12 | 28 | 73 |
| 4164 | 12 | 19 | 28 | 73 |

**Bottom Cleaning Straight Bits
2 flutes**



| ITEM NO. | SHANK DIA. | CUTTER DIA. | CUTTING LENGTH | OVERALL LENGTH |
|----------|------------|-------------|----------------|----------------|
| 4341 | 8 | 6 | 11 | 51 |
| 4342 | 8 | 8 | 19 | 57 |
| 4343 | 8 | 10 | 19 | 51 |
| 4344 | 8 | 12 | 19 | 51 |
| 4345 | 8 | 12 | 25 | 57 |
| 4346 | 8 | 12 | 30 | 62 |
| 4348 | 8 | 14 | 19 | 51 |
| 4349 | 8 | 14 | 25 | 57 |
| 4350 | 8 | 16 | 19 | 51 |
| 4351 | 8 | 16 | 25 | 57 |
| 4352 | 8 | 16 | 30 | 62 |
| 4353 | 8 | 18 | 19 | 51 |
| 4354 | 8 | 18 | 25 | 57 |
| 4355 | 8 | 19 | 19 | 51 |
| 4356 | 8 | 19 | 30 | 62 |
| 4357 | 8 | 20 | 19 | 51 |
| 4381 | 12 | 8 | 19 | 63 |
| 4382 | 12 | 10 | 19 | 63 |
| 4383 | 12 | 12 | 19 | 61 |
| 4384 | 12 | 12 | 25 | 67 |
| 4385 | 12 | 12 | 32 | 73 |
| 4386 | 12 | 12 | 38 | 79 |
| 4387 | 12 | 14 | 19 | 61 |
| 4388 | 12 | 14 | 25 | 67 |
| 4389 | 12 | 16 | 25 | 67 |
| 4390 | 12 | 16 | 32 | 73 |
| 4391 | 12 | 16 | 38 | 79 |
| 4392 | 12 | 18 | 25 | 67 |
| 4393 | 12 | 20 | 25 | 67 |
| 4394 | 12 | 22 | 32 | 73 |

Hinge Mortising Bits

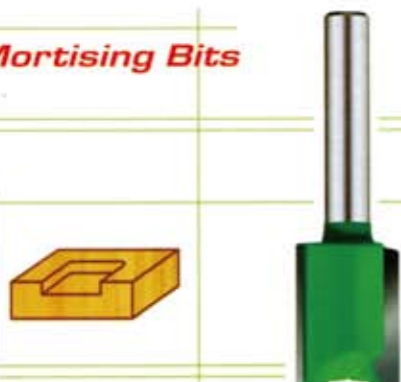

| ITEM NO. | SHANK DIA. | CUTTER DIA. | CUTTING LENGTH | OVERALL LENGTH |
|----------|------------|-------------|----------------|----------------|
| 4091 | 6 | 12 | 19 | 51 |
| 4092 | 6 | 16 | 19 | 51 |
| 4093 | 6 | 19 | 19 | 51 |
| 4101 | 8 | 12 | 19 | 51 |
| 4102 | 8 | 16 | 19 | 51 |
| 4103 | 8 | 19 | 19 | 51 |

Bottom Cleaning Bits



| ITEM NO. | SHANK DIA. | CUTTER DIA. | CUTTING LENGTH | OVERALL LENGTH |
|----------|------------|-------------|----------------|----------------|
| 4151 | 6 | 19 | 14 | 51 |
| 4156 | 8 | 19 | 14 | 51 |
| 4171 | 12 | 19 | 14 | 57 |
| 4172 | 12 | 25 | 11 | 57 |
| 4173 | 12 | 37 | 11 | 57 |

Pattern Bits

**STRAIGHT PATTERN BITS
-WITH UPPER BEARING**



| ITEM NO. | SHANK DIA. | CUTTER DIA. | CUTTING LENGTH |
|----------|------------|-------------|----------------|
| 4291 | 6 | 12.7 | 19.1 |
| 4292 | 6 | 15.90 | 19.1 |
| 4293 | 6 | 19.1 | 19.1 |
| 4296 | 12 | 19.1 | 25.4 |
| 4297 | 12 | 28.6 | 30.2 |

**FLush Trimming Bits
With Bearing**



| ITEM NO. | SHANK DIA. | CUTTER DIA. | CUTTING LENGTH | BEARING SIZE |
|----------|------------|-------------|----------------|--------------|
| 4423 | 6 | 13.00 | 25.4 | 13mm x 5mm |
| 4424 | 6 | 16.00 | 16.0 | 16mm x 5mm |
| 4451 | 8 | 9.50 | 15.0 | 3/8" x 3/16" |
| 4452 | 8 | 9.50 | 30.0 | 3/8" x 3/16" |
| 4453 | 8 | 12.70 | 15.0 | 1/2" x 3/16" |
| 4454 | 8 | 12.70 | 25.4 | 1/2" x 3/16" |
| 4455 | 8 | 12.70 | 30.0 | 1/2" x 3/16" |
| 4456 | 8 | 16.00 | 16.0 | 16mm x 5mm |
| 4457 | 8 | 16.00 | 30.0 | 16mm x 5mm |
| 4458 | 8 | 19.00 | 16.0 | 19mm x 5mm |
| 4481 | 12 | 12.70 | 25.4 | 1/2" x 3/16" |
| 4482 | 12 | 12.70 | 12.7 | 1/2" x 3/16" |
| 4483 | 12 | 12.70 | 38.1 | 1/2" x 3/16" |

**Flush Trimming Bits
2 Flutes**



| ITEM NO. | SHANK DIA. | CUTTER DIA. | CUTTING LENGTH | ANGLE |
|----------|------------|-------------|----------------|-------|
| 4556 | 6 | 12.7 | 12.7 | 23° |
| 4557 | 6 | 12.7 | 12.7 | 30° |
| 4558 | 6 | 12.7 | 12.7 | 35° |
| 4559 | 6 | 12.7 | 12.7 | 45° |
| 4571 | 8 | 12.7 | 12.7 | 23° |
| 4572 | 8 | 12.7 | 12.7 | 30° |
| 4573 | 8 | 12.7 | 12.7 | 35° |
| 4574 | 8 | 12.7 | 12.7 | 45° |

Shear Cut Flush Trim Bits



Cutting edge is angled.

| ITEM NO. | SHANK DIA. | CUTTER DIA. | CUTTING LENGTH |
|----------|------------|-------------|----------------|
| 6451 | 6 | 12.7 | 30 |
| 6452 | 6 | 15.9 | 30 |
| 6461 | 8 | 12.7 | 30 |
| 6462 | 8 | 15.9 | 30 |
| 6471 | 12 | 12.7 | 30 |
| 6472 | 12 | 15.9 | 30 |

**Flush Trim "V" Groove Bit
With Bearing**



| ITEM NO. | SHANK DIA. | CUTTER DIA. | CUTTING LENGTH |
|----------|------------|-------------|----------------|
| 6131 | 6 | 15.9 | 30.2 |
| 6136 | 8 | 15.9 | 30.2 |

Bevel Trimming Bit

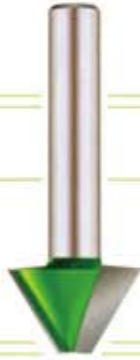

| ITEM NO. | SHANK DIA. | CUTTER DIA. | CUTTING LENGTH | ANGLE |
|----------|------------|-------------|----------------|-------|
| 6201 | 6 | 15.9 | 12.7 | 30° |

**Chamfer Bits
With Bearing**

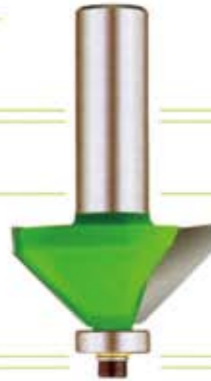

| ITEM NO. | SHANK DIA. | CUTTER DIA. | CUTTING LENGTH | ANGLE |
|----------|------------|-------------|----------------|--------|
| 4601 | 6 | 31.8 | 15 | 45° |
| 4602 | 6 | 34.9 | 15.9 | 45° |
| 4603 | 6 | 19 | 12.7 | 15° |
| 4604 | 6 | 22.2 | 12.7 | 25° |
| 4616 | 8 | 25.4 | 11 | 45° |
| 4617 | 8 | 31.8 | 15 | 45° |
| 4631 | 12 | 31.8 | 15 | 45° |
| 4632 | 12 | 50.8 | 22 | 45° |
| 4633 | 12 | 54 | 28 | 45° |
| 4634 | 12 | 28.6 | 12 | 45° |
| 4635 | 12 | 34.9 | 15.9 | 45° |
| 4636 | 12 | 41.3 | 19 | 45° |
| 4637 | 12 | 47.60 | 22.2 | 45° |
| 4638 | 12 | 22.2 | 25.4 | 11.25° |
| 4639 | 12 | 25.4 | 25.4 | 15° |
| 4640 | 12 | 31.8 | 25.4 | 22.5° |
| 4641 | 12 | 38.1 | 22.2 | 30° |

**Double Roundover Bit
With Bearing**



| ITEM NO. | SHANK DIA. | CUTTER DIA. | CUTTING LENGTH | RADIUS |
|----------|------------|-------------|----------------|--------|
| 4831 | 12 | 31.8 | 28.6 | 4.8 |

**Roundover Bits
With Bearing**



| ITEM NO. | SHANK DIA. | CUTTER DIA. | CUTTING LENGTH | RADIUS | BEARING SIZE |
|----------|------------|-------------|----------------|--------|--------------|
| 4841 | 6 | 15.9 | 7.9 | 1.60 | 1/2" x 3/16" |
| 4842 | 6 | 19.1 | 9.5 | 3.20 | 1/2" x 3/16" |
| 4843 | 6 | 22.2 | 12.7 | 4.80 | 1/2" x 3/16" |
| 4844 | 6 | 25.4 | 12.7 | 6.35 | 1/2" x 3/16" |
| 4845 | 6 | 28.6 | 12.7 | 7.90 | 1/2" x 3/16" |
| 4846 | 6 | 31.8 | 15.9 | 9.50 | 1/2" x 3/16" |
| 4861 | 8 | 15.9 | 7.9 | 1.60 | 1/2" x 3/16" |
| 4862 | 8 | 19.1 | 9.5 | 3.20 | 1/2" x 3/16" |
| 4863 | 8 | 22.2 | 12.7 | 4.80 | 1/2" x 3/16" |
| 4864 | 8 | 25.4 | 12.7 | 6.35 | 1/2" x 3/16" |
| 4865 | 8 | 28.6 | 12.7 | 7.90 | 1/2" x 3/16" |
| 4866 | 8 | 31.8 | 15.9 | 9.50 | 1/2" x 3/16" |
| 4867 | 8 | 38.1 | 19.1 | 12.70 | 1/2" x 3/16" |
| 4881 | 12 | 15.9 | 7.9 | 1.60 | 1/2" x 3/16" |
| 4882 | 12 | 19.1 | 9.5 | 3.20 | 1/2" x 3/16" |
| 4883 | 12 | 22.2 | 12.7 | 4.80 | 1/2" x 3/16" |
| 4884 | 12 | 25.4 | 12.7 | 6.35 | 1/2" x 3/16" |
| 4885 | 12 | 28.6 | 12.7 | 7.90 | 1/2" x 3/16" |
| 4886 | 12 | 31.8 | 15.9 | 9.50 | 1/2" x 3/16" |
| 4887 | 12 | 38.1 | 19.1 | 12.70 | 1/2" x 3/16" |
| 4888 | 12 | 50.8 | 25.4 | 19.10 | 1/2" x 3/16" |

Pattern Bits

**UNDER ROUNDROVER BIT
- WITH UPPER BEARING**



| ITEM NO. | SHANK DIA. | CUTTER DIA. | CUTTING LENGTH | RADIUS |
|----------|------------|-------------|----------------|--------|
| 4891 | 12 | 54 | 19.1 | 9.5 |

**Bevel Bowl Bits
With Bearing**



| ITEM NO. | SHANK DIA. | CUTTER DIA. | CUTTING LENGTH | ANGLE |
|----------|------------|-------------|----------------|-------|
| 4251 | 12 | 25.4 | 19 | 15° |
| 4252 | 12 | 31.8 | 25.4 | 10° |

**Ogee Bowl Bits
With Bearing**



| ITEM NO. | SHANK DIA. | CUTTER DIA. | CUTTING LENGTH | ANGLE |
|----------|------------|-------------|----------------|-------|
| 4261 | 12 | 57.2 | 31.8 | 10° |

**No-Drip Edge Bits
With Bearing**



| ITEM NO. | SHANK DIA. | CUTTER DIA. | CUTTING LENGTH |
|----------|------------|-------------|----------------|
| 4271 | 12 | 20.60 | 19 |
| 4272 | 12 | 20.60 | 22.2 |

**Round Edge Bit
With Bearing**



| ITEM NO. | SHANK DIA. | CUTTER DIA. | CUTTING LENGTH | RADIUS |
|----------|------------|-------------|----------------|--------|
| 4281 | 12 | 41.3 | 19 | 10.3 |

**Handrail Bits & Finger Grip Bits
With Bearing**



• Handrail Bits

| ITEM NO. | SHANK DIA. | CUTTER DIA. | CUTTING LENGTH |
|----------|------------|-------------|----------------|
| 4361 | 12 | 69.9 | 28.6 |
| 4362 | 12 | 79.4 | 28.6 |

• Finger Grip Bits

| ITEM NO. | SHANK DIA. | CUTTER DIA. | CUTTING LENGTH |
|----------|------------|-------------|----------------|
| 4371 | 12 | 28.6 | 38.1 |
| 4372 | 12 | 31.8 | 38.1 |
| 4373 | 12 | 31.8 | 38.1 |

**Beading Bits
With Bearing**



| ITEM NO. | SHANK DIA. | CUTTER DIA. | CUTTING LENGTH | RADIUS | BEARING SIZE |
|----------|------------|-------------|----------------|--------|--------------|
| 4781 | 6 | 15.9 | 7.9 | 1.60 | 3/8 x 3/16' |
| 4782 | 6 | 19.1 | 9.5 | 3.20 | 3/8 x 3/16' |
| 4783 | 6 | 22.2 | 12.7 | 4.80 | 3/8 x 3/16' |
| 4784 | 6 | 25.4 | 12.7 | 6.35 | 3/8 x 3/16' |
| 4785 | 6 | 28.6 | 12.7 | 7.90 | 3/8 x 3/16' |
| 4786 | 6 | 31.8 | 15.9 | 9.50 | 3/8 x 3/16' |
| 4787 | 6 | 38.1 | 19.1 | 12.70 | 3/8 x 3/16' |
| 4801 | 8 | 15.9 | 7.9 | 1.60 | 3/8 x 3/16' |
| 4802 | 8 | 19.1 | 9.5 | 3.20 | 3/8 x 3/16' |
| 4803 | 8 | 22.2 | 12.7 | 4.80 | 3/8 x 3/16' |
| 4804 | 8 | 25.4 | 12.7 | 6.35 | 3/8 x 3/16' |
| 4805 | 8 | 28.6 | 12.7 | 7.90 | 3/8 x 3/16' |
| 4806 | 8 | 31.8 | 15.9 | 9.50 | 3/8 x 3/16' |
| 4807 | 8 | 38.1 | 19.1 | 12.70 | 3/8 x 3/16' |
| 4821 | 12 | 19.1 | 9.5 | 3.20 | 3/8 x 3/16' |
| 4822 | 12 | 22.2 | 12.7 | 4.80 | 3/8 x 3/16' |
| 4823 | 12 | 25.4 | 12.7 | 6.35 | 3/8 x 3/16' |
| 4824 | 12 | 28.6 | 12.7 | 7.90 | 3/8 x 3/16' |
| 4825 | 12 | 31.8 | 15.9 | 9.50 | 3/8 x 3/16' |
| 4826 | 12 | 38.1 | 19.1 | 12.70 | 3/8 x 3/16' |

**Multiple Beading Bit
With Two Bearings**



| ITEM NO. | SHANK DIA. | CUTTER DIA. | CUTTING LENGTH | d |
|----------|------------|-------------|----------------|-----|
| 4851 | 6 | 23.80 | 22.2 | 9.5 |

**Cove Bits
With Bearing**



| ITEM NO. | SHANK DIA. | CUTTER DIA. | CUTTING LENGTH | RADIUS | BEARING SIZE |
|----------|------------|-------------|----------------|--------|--------------|
| 5051 | 6 | 19.1 | 14.3 | 4.80 | 3/8" x 3/16" |
| 5052 | 6 | 22.2 | 14.3 | 6.35 | 3/8" x 3/16" |
| 5053 | 6 | 25.4 | 14.3 | 7.90 | 3/8" x 3/16" |
| 5054 | 6 | 28.6 | 14.3 | 9.50 | 3/8" x 3/16" |
| 5055 | 6 | 34.9 | 16.0 | 12.70 | 3/8" x 3/16" |
| 5076 | 8 | 19.1 | 14.3 | 4.80 | 3/8" x 3/16" |
| 5077 | 8 | 22.2 | 14.3 | 6.35 | 3/8" x 3/16" |
| 5078 | 8 | 25.4 | 14.3 | 7.90 | 3/8" x 3/16" |
| 5079 | 8 | 28.6 | 14.3 | 9.50 | 3/8" x 3/16" |
| 5080 | 8 | 34.9 | 16.0 | 12.70 | 3/8" x 3/16" |
| 5081 | 8 | 19.1 | 12.7 | 3.20 | 1/2" x 3/16" |
| 5082 | 8 | 22.2 | 12.7 | 4.8 | 1/2" x 3/16" |
| 5083 | 8 | 25.4 | 12.7 | 6.35 | 1/2" x 3/16" |
| 5084 | 8 | 28.6 | 12.7 | 7.90 | 1/2" x 3/16" |
| 5085 | 8 | 31.8 | 16.0 | 9.50 | 1/2" x 3/16" |
| 5086 | 8 | 38.1 | 16.0 | 12.70 | 1/2" x 3/16" |
| 5101 | 12 | 22.2 | 14.3 | 6.35 | 3/8" x 3/16" |
| 5102 | 12 | 25.4 | 14.3 | 7.90 | 3/8" x 3/16" |
| 5103 | 12 | 28.6 | 14.3 | 9.50 | 3/8" x 3/16" |
| 5104 | 12 | 34.9 | 16.0 | 12.70 | 3/8" x 3/16" |

Pattern Bits

**DOVETAIL PATTERN BIT
-WITH UPPER BEARING**

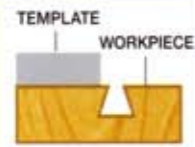

| ITEM NO. | SHANK DIA. | CUTTER DIA. | CUTTING LENGTH | ANGLE |
|----------|------------|-------------|----------------|-------|
| 5551 | 6 | 12.7 | 12.7 | 14° |

Dovetail Bits



| ITEM NO. | SHANK DIA. | CUTTER DIA. | CUTTING LENGTH | ANGLE |
|----------|------------|-------------|----------------|-------|
| 5561 | 6 | 9.5 | 9.5 | 9° |
| 5562 | 6 | 12.7 | 12.7 | 14° |
| 5563 | 6 | 6.35 | 7.9 | 7° |
| 5564 | 6 | 7.90 | 9.5 | 8° |
| 5565 | 6 | 13.50 | 12.7 | 14° |
| 5566 | 6 | 14.30 | 12.7 | 14° |
| 5567 | 6 | 19.1 | 19.1 | 14° |
| 5568 | 6 | 9.5 | 9.5 | 8° |
| 5569 | 6 | 12.7 | 15.8 | 8° |
| 5581 | 8 | 9.5 | 9.5 | 9° |
| 5582 | 8 | 12.7 | 12.7 | 14° |
| 5583 | 8 | 15.9 | 15.9 | 7° |
| 5584 | 8 | 19.1 | 19.1 | 14° |
| 5601 | 12 | 15.9 | 15.9 | 7° |
| 5602 | 12 | 19.1 | 19.1 | 14° |
| 5603 | 12 | 22.2 | 22.2 | 14° |
| 5604 | 12 | 25.4 | 25.4 | 14° |
| 5605 | 12 | 17.50 | 22.2 | 8° |
| 5606 | 12 | 20.7 | 28.6 | 8° |
| 5607 | 12 | 13.50 | 12.7 | 14° |
| 5608 | 12 | 12.7 | 12.7 | 14° |
| 5609 | 12 | 19 | 28.6 | 7° |

**Slotting Bits
4 Flutes With Bearing**



**Rabbeting Bits
With Bearing**



**Rabbeting Bits
with Bearing Sets**

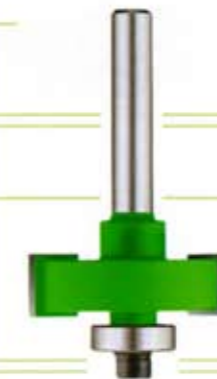

| ITEM NO. | SHANK DIA. | CUTTER DIA. | CUTTING LENGTH |
|----------|------------|-------------|----------------|
| 5201 | 6 | 47.6 | 3 |
| 5202 | 6 | 47.6 | 4 |
| 5203 | 6 | 47.6 | 5 |
| 5204 | 6 | 47.6 | 6 |
| 5211 | 8 | 47.6 | 3 |
| 5212 | 8 | 47.6 | 4 |
| 5213 | 8 | 47.6 | 5 |
| 5214 | 8 | 47.6 | 6 |
| 5221 | 12 | 47.6 | 3 |
| 5222 | 12 | 47.6 | 4 |
| 5223 | 12 | 47.6 | 5 |
| 5224 | 12 | 47.6 | 6 |
| 5231 | 6 | 50.8 | 3 |
| 5232 | 6 | 50.8 | 4 |
| 5233 | 6 | 50.8 | 5 |
| 5234 | 6 | 50.8 | 6 |
| 5241 | 8 | 50.8 | 3 |
| 5242 | 8 | 50.8 | 4 |
| 5243 | 8 | 50.8 | 5 |
| 5244 | 8 | 50.8 | 6 |
| 5251 | 12 | 50.8 | 3 |
| 5252 | 12 | 50.8 | 4 |
| 5253 | 12 | 50.8 | 5 |
| 5254 | 12 | 50.8 | 6 |

| ITEM NO. | SHANK DIA. | CUTTER DIA. | CUTTING LENGTH | CUTTING DEPTH |
|----------|------------|-------------|----------------|---------------|
| 5951 | 6 | 31.8 | 1.6 | 9.5 |
| 5952 | 6 | 31.8 | 3.2 | 9.5 |
| 5953 | 6 | 31.8 | 4 | 9.5 |
| 5954 | 6 | 31.8 | 4.8 | 9.5 |
| 5955 | 6 | 31.8 | 6.35 | 9.5 |
| 5956 | 6 | 31.8 | 9.5 | 9.5 |
| 5957 | 6 | 31.8 | 12.7 | 9.5 |
| 5966 | 8 | 31.8 | 1.6 | 9.5 |
| 5967 | 8 | 31.8 | 3.2 | 9.5 |
| 5968 | 8 | 31.8 | 4 | 9.5 |
| 5969 | 8 | 31.8 | 4.8 | 9.5 |
| 5970 | 8 | 31.8 | 6.35 | 9.5 |
| 5971 | 8 | 31.8 | 9.5 | 9.5 |
| 5972 | 8 | 31.8 | 12.70 | 9.5 |
| 5981 | 12 | 31.8 | 3.2 | 9.5 |
| 5982 | 12 | 31.8 | 6.35 | 9.5 |
| 5983 | 12 | 31.8 | 9.5 | 9.5 |
| 5984 | 12 | 31.8 | 12.7 | 9.5 |
| 5985 | 12 | 31.8 | 15.9 | 9.5 |
| 5986 | 12 | 31.8 | 19.1 | 9.5 |

COMPLETE KIT INCLUDES 1 RABBETING BIT, 4 BEARINGS, HEXKEY, WASHER, AND SCREW.

| ITEM NO. | SHANK DIA. | CUTTER DIA. | CUTTING LENGTH |
|----------|------------|-------------|----------------|
| 6026 | 8 | 31.8 | 3.2 |
| 6027 | 8 | 31.8 | 6.35 |
| 6028 | 8 | 31.8 | 9.5 |
| 6029 | 8 | 31.8 | 12.7 |



Pattern Bits

CORE BOX PATTERN BIT
- WITH UPPER BEARING

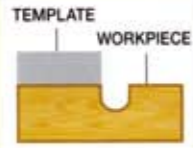

| ITEM NO. | SHANK DIA. | CUTTER DIA. | CUTTING LENGTH | RADIUS |
|----------|------------|-------------|----------------|--------|
| 5681 | 6 | 12.7 | 15.9 | 6.35 |

Core Box Bits



| ITEM NO. | SHANK DIA. | CUTTER DIA. | CUTTING LENGTH | RADIUS |
|----------|------------|-------------|----------------|--------|
| 5695 | 6 | 6.35 | 6.35 | 3.2 |
| 5696 | 6 | 9.5 | 6.35 | 4.80 |
| 5697 | 6 | 12.7 | 9.5 | 6.35 |
| 5698 | 6 | 15.9 | 11.0 | 7.90 |
| 5699 | 6 | 19.1 | 12.7 | 9.50 |
| 5716 | 8 | 9.5 | 6.35 | 4.80 |
| 5717 | 8 | 12.7 | 9.5 | 6.35 |
| 5718 | 8 | 15.9 | 11.0 | 7.90 |
| 5719 | 8 | 19.1 | 12.7 | 9.50 |
| 5720 | 8 | 22.2 | 15.9 | 11.10 |
| 5721 | 8 | 25.4 | 15.9 | 12.70 |
| 5736 | 12 | 9.5 | 6.35 | 4.80 |
| 5737 | 12 | 12.7 | 9.5 | 6.35 |
| 5738 | 12 | 15.9 | 11.0 | 7.90 |
| 5739 | 12 | 19.1 | 12.7 | 9.5 |
| 5740 | 12 | 22.2 | 15.9 | 11.10 |
| 5741 | 12 | 25.4 | 15.9 | 12.70 |
| 5742 | 12 | 38.1 | 25.4 | 19.1 |

Roundnose Bits



| ITEM NO. | SHANK DIA. | CUTTER DIA. | CUTTING LENGTH | RADIUS |
|----------|------------|-------------|----------------|--------|
| 5763 | 6 | 6.35 | 9.5 | 3.2 |
| 5764 | 6 | 9.5 | 11.1 | 4.8 |
| 5765 | 6 | 12.7 | 14.3 | 6.35 |
| 5766 | 8 | 9.5 | 25.4 | 4.80 |
| 5767 | 8 | 12.7 | 31.8 | 6.35 |
| 5768 | 8 | 14.3 | 31.8 | 7.10 |
| 5769 | 8 | 15.9 | 31.8 | 7.90 |
| 5770 | 8 | 19.0 | 31.8 | 9.50 |
| 5771 | 8 | 22.2 | 31.8 | 11.10 |
| 5772 | 8 | 25.4 | 31.8 | 12.70 |
| 5781 | 12 | 9.5 | 25.4 | 4.80 |
| 5782 | 12 | 12.7 | 31.8 | 6.35 |
| 5783 | 12 | 14.3 | 31.8 | 7.10 |
| 5784 | 12 | 15.9 | 31.8 | 7.90 |
| 5785 | 12 | 19.0 | 31.8 | 9.50 |
| 5786 | 12 | 22.2 | 31.8 | 11.10 |
| 5787 | 12 | 25.4 | 31.8 | 12.70 |

Plunging Ball Bits



| ITEM NO. | SHANK DIA. | CUTTER DIA. | CUTTING LENGTH | RADIUS |
|----------|------------|-------------|----------------|--------|
| 5861 | 6 | 12.7 | 11.1 | 6.35 |
| 5862 | 6 | 19.1 | 15.9 | 9.5 |
| 5871 | 8 | 12.7 | 11.1 | 6.35 |
| 5872 | 8 | 19.1 | 15.9 | 9.5 |
| 5881 | 12 | 12.7 | 11.1 | 6.35 |
| 5882 | 12 | 15.9 | 12.7 | 7.90 |
| 5883 | 12 | 19.1 | 15.9 | 9.5 |
| 5884 | 12 | 25.4 | 23.8 | 12.7 |
| 5885 | 12 | 31.8 | 28.6 | 15.9 |

Roman Ogee Bits With Bearing



| ITEM NO. | SHANK DIA. | CUTTER DIA. | CUTTING LENGTH | RADIUS | BEARING SIZE |
|----------|------------|-------------|----------------|--------|--------------|
| 5121 | 6 | 28.6 | 12.7 | 4 | 3/16" x 1/2" |
| 5122 | 6 | 38.1 | 19.1 | 6.35 | 3/16" x 1/2" |
| 5123 | 8 | 28.6 | 12.7 | 4 | 3/16" x 1/2" |
| 5124 | 8 | 38.1 | 19.1 | 6.35 | 3/16" x 1/2" |
| 5125 | 12 | 28.6 | 12.7 | 4 | 3/16" x 1/2" |
| 5128 | 12 | 31.8 | 19.1 | 6.35 | 3/16" x 1/2" |

Stepped Ogee Bit With Bearing



| ITEM NO. | SHANK DIA. | CUTTER DIA. | CUTTING LENGTH | CUTTING WIDTH |
|----------|------------|-------------|----------------|---------------|
| 5141 | 12 | 57.20 | 19.1 | 20.70 |

Beading / Roundover Bits



| ITEM NO. | SHANK DIA. | CUTTER DIA. | CUTTING LENGTH | RADIUS |
|----------|------------|-------------|----------------|--------|
| 4736 | 6 | 19.1 | 12.7 | 6.35 |
| 4737 | 6 | 22.2 | 14.3 | 7.90 |
| 4738 | 6 | 25.4 | 15.9 | 9.53 |
| 4751 | 8 | 9.5 | 11.0 | 3.20 |
| 4752 | 8 | 15.9 | 12.7 | 6.35 |
| 4753 | 8 | 19.1 | 12.7 | 6.35 |
| 4754 | 8 | 22.2 | 14.3 | 7.90 |
| 4755 | 8 | 25.4 | 15.9 | 9.53 |
| 4756 | 8 | 34.9 | 25.4 | 12.70 |
| 4766 | 12 | 19.1 | 12.7 | 6.35 |
| 4767 | 12 | 22.2 | 14.3 | 7.90 |
| 4768 | 12 | 25.4 | 15.9 | 9.53 |
| 4769 | 12 | 34.9 | 25.4 | 12.70 |
| 4770 | 12 | 44.5 | 31.8 | 15.90 |
| 4771 | 12 | 50.8 | 36.5 | 19.10 |

Plunging Roundover Bits

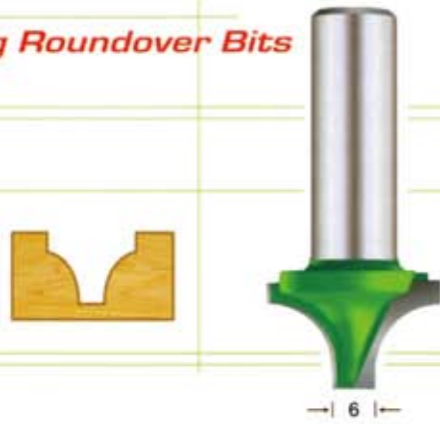

| ITEM NO. | SHANK DIA. | CUTTER DIA. | CUTTING LENGTH | SHANK LENGTH | RADIUS |
|----------|------------|-------------|----------------|--------------|--------|
| 4301 | 6 | 25.4 | 15.9 | 31.8 | 9.5 |
| 4302 | 12 | 25.4 | 15.9 | 38.1 | 9.5 |

Plunging Bead Bits

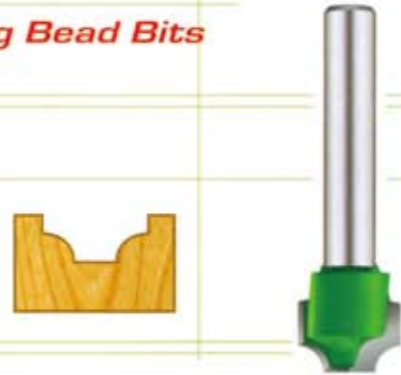

| ITEM NO. | SHANK DIA. | CUTTER DIA. | CUTTING LENGTH | SHANK LENGTH | RADIUS |
|----------|------------|-------------|----------------|--------------|--------|
| 4311 | 6 | 12.7 | 9.5 | 31.8 | 3.2 |
| 4312 | 12 | 12.7 | 9.5 | 38.1 | 3.2 |

Plunging Quarter Bead Bits

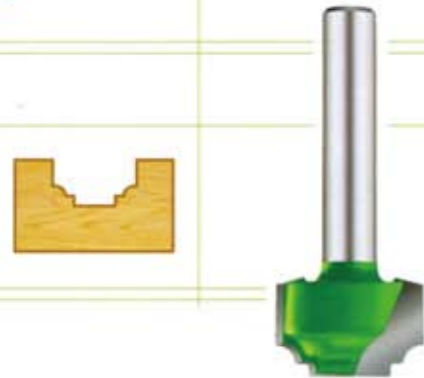

| ITEM NO. | SHANK DIA. | CUTTER DIA. | CUTTING LENGTH | SHANK LENGTH | RADIUS |
|----------|------------|-------------|----------------|--------------|--------|
| 4321 | 6 | 17.5 | 11.1 | 31.8 | 2.4 |
| 4322 | 12 | 17.5 | 11.1 | 38.1 | 2.4 |

Plunging Ogee Bits



| ITEM NO. | SHANK DIA. | CUTTER DIA. | CUTTING LENGTH | RADIUS |
|----------|------------|-------------|----------------|--------|
| 4901 | 6 | 9.5 | 7.9 | 1.6 |
| 4902 | 6 | 12.7 | 9.5 | 2.0 |
| 4903 | 6 | 19.1 | 12.5 | 3.2 |
| 4916 | 8 | 9.5 | 7.9 | 1.6 |
| 4917 | 8 | 12.7 | 9.5 | 2.0 |
| 4918 | 8 | 19.1 | 12.5 | 3.2 |
| 4931 | 12 | 9.5 | 7.9 | 1.6 |
| 4932 | 12 | 12.7 | 9.5 | 2.0 |
| 4933 | 12 | 19.1 | 12.5 | 3.2 |

Classical Plunge Bits

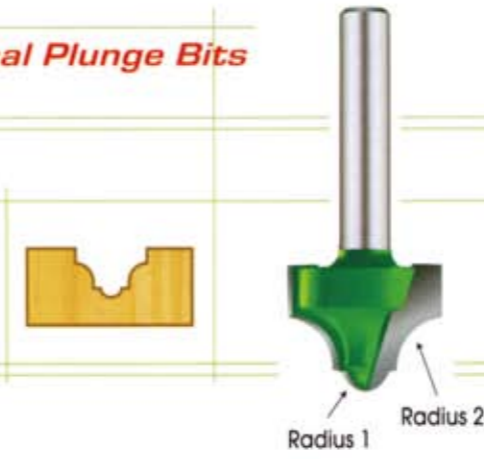

| ITEM NO. | SHANK DIA. | CUTTER DIA. | CUTTING LENGTH | RADIUS 1 | RADIUS 2 |
|----------|------------|-------------|----------------|----------|----------|
| 4946 | 6 | 12.7 | 10.5 | 2.5 | 3.5 |
| 4947 | 6 | 19.1 | 12.7 | 3.7 | 4.0 |
| 4961 | 8 | 12.7 | 10.5 | 2.5 | 3.5 |
| 4962 | 8 | 19.1 | 12.7 | 3.7 | 4.0 |
| 4963 | 8 | 25.4 | 17.0 | 5.0 | 6.5 |
| 4976 | 12 | 12.7 | 10.5 | 2.5 | 3.5 |
| 4977 | 12 | 19.1 | 12.7 | 3.7 | 4.0 |
| 4978 | 12 | 25.4 | 17.0 | 5.0 | 6.5 |

Classical Plunge Pattern Bits I With Upper Bearing

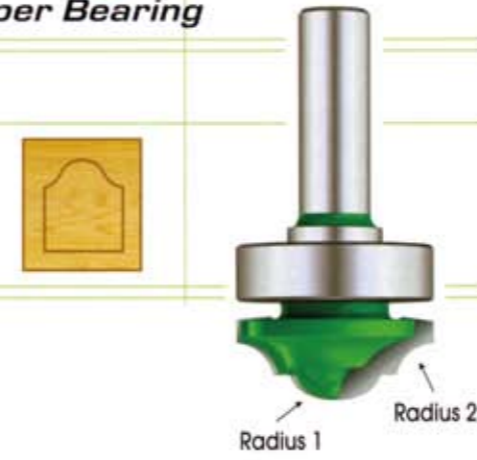

| ITEM NO. | SHANK DIA. | CUTTER DIA. | CUTTING LENGTH | RADIUS 1 | RADIUS 2 |
|----------|------------|-------------|----------------|----------|----------|
| 4991 | 6 | 22 | 12.7 | 5.5 | 4.0 |
| 5001 | 8 | 22 | 12.7 | 5.5 | 4.0 |
| 5011 | 12 | 35 | 12.7 | 5.5 | 4.0 |

Classical Plunge Pattern Bits II With Upper Bearing

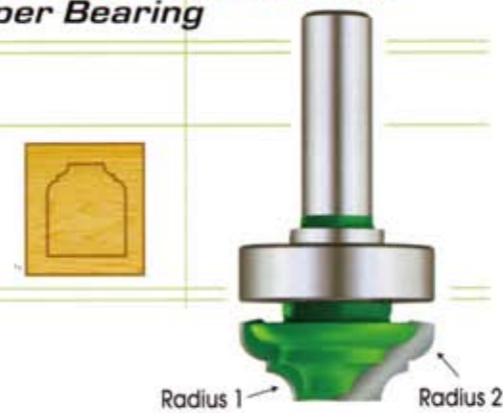

| ITEM NO. | SHANK DIA. | CUTTER DIA. | CUTTING LENGTH | RADIUS 1 | RADIUS 2 |
|----------|------------|-------------|----------------|----------|----------|
| 5021 | 6 | 22 | 9.5 | 2.4 | 2.4 |
| 5031 | 8 | 22 | 9.5 | 2.4 | 2.4 |
| 5042 | 12 | 35 | 14.3 | 5.0 | 5.0 |

Dish Cutter Bits

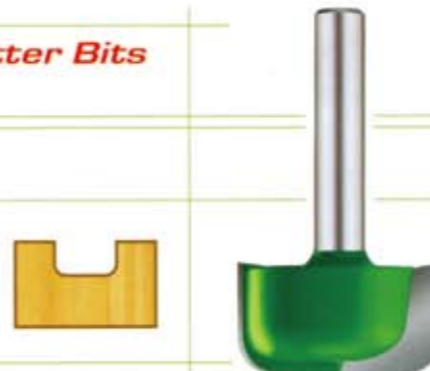

| ITEM NO. | SHANK DIA. | CUTTER DIA. | CUTTING LENGTH | RADIUS |
|----------|------------|-------------|----------------|--------|
| 5161 | 6 | 25.4 | 12.7 | 4.8 |
| 5171 | 8 | 31.8 | 12.7 | 4.8 |
| 5181 | 12 | 31.8 | 12.7 | 4.8 |

Fingernail (Half Radius) Bits

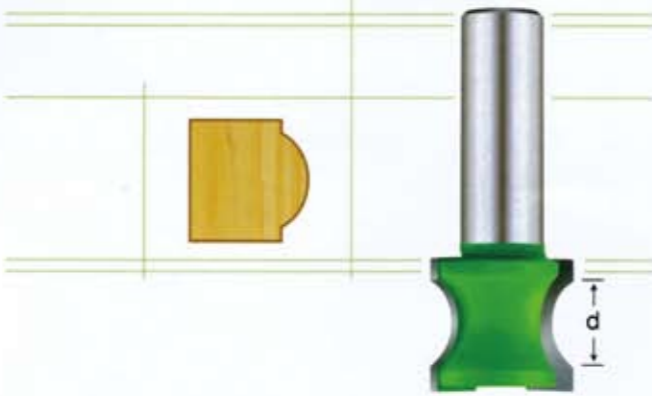

| ITEM NO. | SHANK DIA. | CUTTER DIA. | CUTTING LENGTH | d |
|----------|------------|-------------|----------------|------|
| 4701 | 6 | 19 | 15.8 | 9.5 |
| 4702 | 6 | 19 | 19 | 12.7 |
| 4703 | 6 | 22.2 | 25.4 | 19 |
| 4706 | 8 | 19 | 15.8 | 9.5 |
| 4707 | 8 | 19 | 19 | 12.7 |
| 4708 | 8 | 22.2 | 25.4 | 19 |
| 4711 | 12 | 22.2 | 14.3 | 9.5 |
| 4712 | 12 | 22.2 | 19 | 12.7 |
| 4713 | 12 | 25.4 | 25.4 | 19 |
| 4714 | 12 | 25.4 | 34.9 | 25.4 |
| 4715 | 12 | 28.6 | 44.5 | 38.1 |

Bull Nose Bits

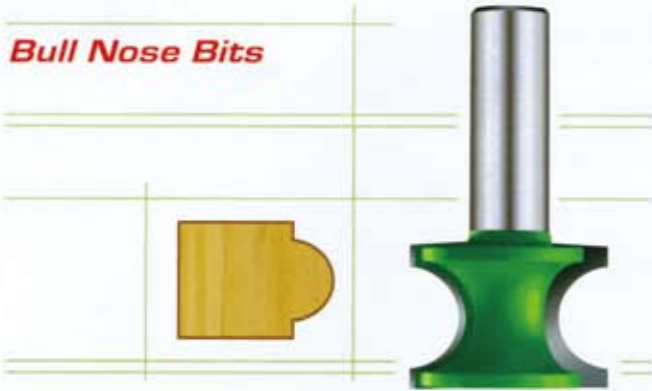

| ITEM NO. | SHANK DIA. | CUTTER DIA. | CUTTING LENGTH | RADIUS |
|----------|------------|-------------|----------------|--------|
| 4661 | 8 | 13.5 | 12.7 | 2.00 |
| 4662 | 8 | 15.1 | 12.7 | 2.80 |
| 4663 | 8 | 15.9 | 12.7 | 3.20 |
| 4664 | 8 | 16.7 | 19.1 | 3.60 |
| 4665 | 8 | 22.2 | 17.0 | 4.80 |
| 4666 | 8 | 22.2 | 19.1 | 5.20 |
| 4667 | 8 | 25.4 | 20.0 | 6.35 |
| 4668 | 8 | 26.1 | 25.4 | 6.80 |
| 4676 | 12 | 22.2 | 19.1 | 5.20 |
| 4677 | 12 | 26.1 | 25.4 | 6.80 |
| 4678 | 12 | 33.3 | 35.0 | 9.50 |

V-Groove Bits

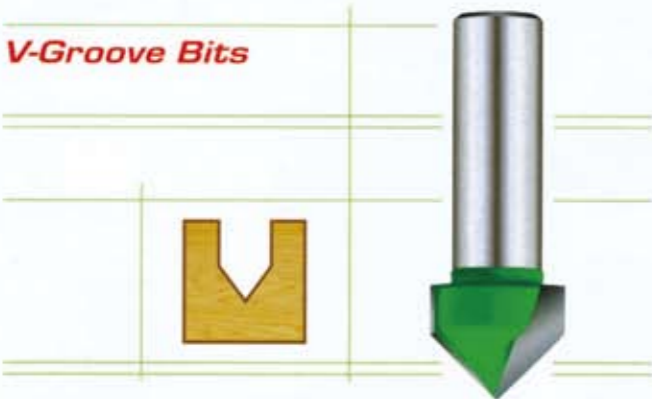

| ITEM NO. | SHANK DIA. | CUTTER DIA. | CUTTING LENGTH | ANGLE |
|----------|------------|-------------|----------------|-------|
| 5621 | 6 | 9.5 | 11.0 | 90° |
| 5622 | 6 | 12.7 | 16.0 | 60° |
| 5623 | 6 | 12.7 | 12.7 | 90° |
| 5624 | 6 | 15.9 | 12.7 | 90° |
| 5625 | 6 | 19.1 | 15.9 | 90° |
| 5626 | 6 | 25.4 | 19.1 | 90° |
| 5646 | 8 | 9.5 | 11.0 | 90° |
| 5647 | 8 | 12.7 | 16.0 | 60° |
| 5648 | 8 | 12.7 | 12.7 | 90° |
| 5649 | 8 | 15.9 | 12.7 | 90° |
| 5650 | 8 | 19.1 | 15.9 | 90° |
| 5651 | 8 | 25.4 | 19.1 | 90° |
| 5652 | 8 | 31.8 | 32.0 | 90° |
| 5653 | 8 | 38.1 | 38.0 | 90° |
| 5671 | 12 | 9.5 | 11.0 | 90° |
| 5672 | 12 | 12.7 | 16.0 | 60° |
| 5673 | 12 | 12.7 | 12.7 | 90° |
| 5674 | 12 | 15.9 | 12.7 | 90° |
| 5675 | 12 | 19.1 | 15.9 | 90° |
| 5676 | 12 | 25.4 | 19.1 | 90° |
| 5677 | 12 | 31.8 | 32.0 | 90° |
| 5678 | 12 | 38.1 | 38.0 | 90° |

Pattern Bits

90° V-GROOVE PATTERN BIT - WITH UPPER BEARING

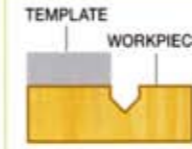

| ITEM NO. | SHANK DIA. | CUTTER DIA. | CUTTING LENGTH | ANGLE |
|----------|------------|-------------|----------------|-------|
| 5611 | 6 | 12.7 | 12.7 | 90° |

Tongue & Groove Assembly With Bearing

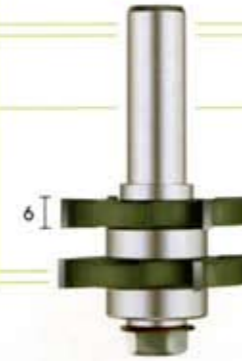

COMPLETE KIT INCLUDES 2 CUTTERS, ARBOR, 2 BEARINGS, AND SHIM SET.

| ITEM NO. | SHANK DIA. | CUTTER DIA. | CUTTING LENGTH | CUTTING DEPTH |
|----------|------------|-------------|----------------|---------------|
| 5816 | 8 | 44.5 | 19 | 11.11 |
| 5821 | 12 | 44.5 | 19 | 11.11 |

Tongue & Groove V-match Set With Bearing



| ITEM NO. | SHANK DIA. | CUTTER DIA. | CUTTING LENGTH |
|----------|------------|-------------|----------------|
| 5831 | 12 | 36.5 | 25.4 |

Tongue & Groove Set

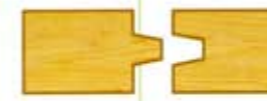

| ITEM NO. | SHANK DIA. | CUTTER DIA. | CUTTING LENGTH |
|----------|------------|-------------|----------------|
| 5851 | 12 | 36.5 | 25.4 |

Reversible Tongue & Groove Bits



| ITEM NO. | DESCRIPTION | SHANK DIA. | CUTTER DIA. | CUTTING LENGTH |
|----------|-------------|------------|-------------|----------------|
| 5911 | WEDGE | 12 | 41.3 | 25.4 |
| 5912 | STRAIGHT | 12 | 41.3 | 25.4 |

Drawer Lock Bits



| ITEM NO. | SHANK DIA. | CUTTER DIA. | CUTTING LENGTH |
|----------|------------|-------------|----------------|
| 6071 | 12 | 27 | 19.1 |
| 6072 | 12 | 50.8 | 12.7 |

Glue Joint Bits



| ITEM NO. | SHANK DIA. | CUTTER DIA. | CUTTING LENGTH |
|----------|------------|-------------|----------------|
| 6081 | 6 | 25.4 | 30.2 |
| 6086 | 8 | 25.4 | 30.2 |
| 6091 | 12 | 28.6 | 31.8 |

Corner Lock Miter Bit



| ITEM NO. | SHANK DIA. | CUTTER DIA. | CUTTING LENGTH |
|----------|------------|-------------|----------------|
| 6101 | 6 | 41.3 | 17 |
| 6106 | 8 | 41.3 | 17 |
| 6121 | 12 | 41.3 | 17 |
| 6122 | 12 | 76.2 | 25.4 |

Finger Joint Bits With Bearing



| ITEM NO. | SHANK DIA. | CUTTER DIA. | JOINT LENGTH | BEARING SIZE |
|----------|------------|-------------|--------------|--------------|
| 5801 | 8 | 39.7 | 11-36 | 22 x 8 |
| 5806 | 12 | 39.7 | 11-36 | 22 x 8 |

Finger Joint Bit With Bearing



| ITEM NO. | SHANK DIA. | CUTTER DIA. | CUTTING LENGTH |
|----------|------------|-------------|----------------|
| 5991 | 12 | 41.3 | 25.4 |

Edge Beading Bits I With Bearing



| ITEM NO. | SHANK DIA. | CUTTER DIA. | CUTTING LENGTH | d |
|----------|------------|-------------|----------------|------|
| 4501 | 6 | 20.7 | 63.5 | 6.35 |
| 4506 | 12 | 19.1 | 19.1 | 3.2 |
| 4507 | 12 | 22.2 | 20.7 | 6.35 |
| 4508 | 12 | 25.4 | 20.7 | 9.5 |

Edge Beading Bits II With Bearing



| ITEM NO. | SHANK DIA. | CUTTER DIA. | CUTTING LENGTH | d |
|----------|------------|-------------|----------------|------|
| 4521 | 6 | 17.5 | 14.3 | 4.8 |
| 4522 | 6 | 20.7 | 19.1 | 7.90 |
| 4531 | 8 | 17.5 | 14.3 | 4.8 |
| 4532 | 8 | 20.7 | 19.1 | 7.90 |

**Edge Beading Bits III
With Bearing**



| ITEM NO. | SHANK DIA. | CUTTER DIA. | CUTTING LENGTH | d |
|----------|------------|-------------|----------------|------|
| 4541 | 6 | 20.7 | 22.2 | 7.9 |
| 4546 | 12 | 20.7 | 22.2 | 7.9 |
| 4547 | 12 | 25.4 | 25.4 | 12.7 |

**Corner Beading Bits
With Bearing**



| ITEM NO. | SHANK DIA. | CUTTER DIA. | CUTTING LENGTH | d |
|----------|------------|-------------|----------------|------|
| 4561 | 6 | 15.9 | 6.35 | 3.2 |
| 4562 | 6 | 17.5 | 7.90 | 4.8 |
| 4563 | 6 | 19.1 | 12.7 | 6.35 |
| 4581 | 12 | 25.4 | 15.9 | 9.5 |
| 4582 | 12 | 28.6 | 20.7 | 12.7 |
| 4583 | 12 | 30.2 | 22.2 | 15.9 |
| 4584 | 12 | 33.3 | 27 | 19.1 |

Flute And Bead Set

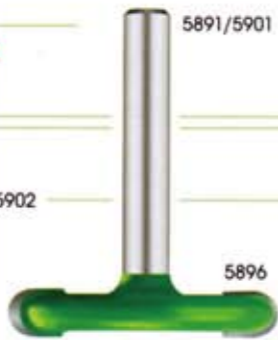

| ITEM NO. | DESCRIPTION | SHANK DIA. | CUTTER DIA. | CUTTING LENGTH |
|----------|-------------|------------|-------------|----------------|
| 5891 | FLUTE | 6 | 38.1 | 6.35 |
| 5892 | BEAD | 6 | 38.1 | 12.7 |
| 5896 | FLUTE | 8 | 38.1 | 6.35 |
| 5897 | BEAD | 8 | 38.1 | 12.7 |
| 5901 | FLUTE | 12 | 38.1 | 6.35 |
| 5902 | BEAD | 12 | 38.1 | 12.7 |

T-Slot Bit



| ITEM NO. | SHANK DIA. | CUTTER DIA. | CUTTING LENGTH | T-WIDTH |
|----------|------------|-------------|----------------|---------|
| 6001 | 12 | 25.4 | 22.2 | 9.5 |

**Key Hole Bits
1 Flute**



| ITEM NO. | SHANK DIA. | CUTTER DIA. | CUTTING LENGTH | SHANK LENGTH |
|----------|------------|-------------|----------------|--------------|
| 6011 | 6 | 12.7 | 12.7 | 31.8 |
| 6012 | 6 | 9.5 | 11.1 | 31.8 |

**Panel Pilot Bits
1 Flute**



| ITEM NO. | SHANK DIA. | CUTTER DIA. | CUTTING LENGTH | SHANK LENGTH |
|-----------|------------|-------------|----------------|--------------|
| 6041 (1F) | 6 | 6 | 19.1 | 31.8 |
| 6042 (2F) | 6 | 6 | 19.1 | 31.8 |
| 6051 (1F) | 12 | 12 | 28.6 | 38.1 |
| 6052 (2F) | 12 | 12 | 28.6 | 38.1 |

**Thumbnail
With Bearing**



| ITEM NO. | SHANK DIA. | CUTTER DIA. | CUTTING LENGTH | CUTTING WIDTH |
|----------|------------|-------------|----------------|---------------|
| 5191 | 12 | 63.5 | 22.2 | 25.4 |

**Classical Cove & Bead Bits
With Bearing**



| ITEM NO. | SHANK DIA. | CUTTER DIA. | CUTTING LENGTH | CUTTING WIDTH |
|----------|------------|-------------|----------------|---------------|
| 5271 | 6 | 31.8 | 15.9 | 9.5 |
| 5272 | 6 | 38.1 | 19.1 | 12.7 |
| 5273 | 8 | 31.8 | 15.9 | 9.5 |
| 5274 | 8 | 38.1 | 19.1 | 12.7 |
| 5281 | 12 | 31.8 | 15.9 | 9.5 |
| 5282 | 12 | 38.1 | 19.1 | 12.7 |

**Classical Roman Ogee Bits
With Bearing**

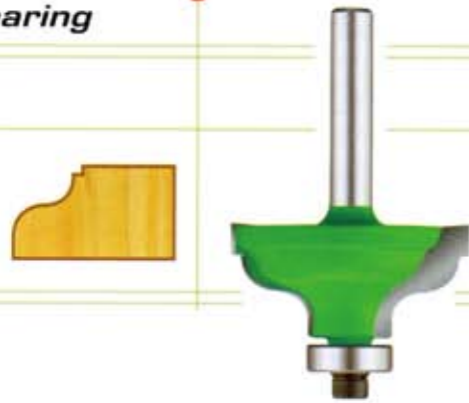

| ITEM NO. | SHANK DIA. | CUTTER DIA. | CUTTING LENGTH | CUTTING WIDTH |
|----------|------------|-------------|----------------|---------------|
| 5331 | 6 | 31.8 | 14.3 | 9.5 |
| 5332 | 6 | 34.9 | 15.9 | 11.1 |
| 5333 | 8 | 31.8 | 14.3 | 9.5 |
| 5337 | 8 | 34.9 | 15.9 | 11.1 |
| 5341 | 12 | 31.8 | 14.3 | 9.5 |
| 5342 | 12 | 34.9 | 15.9 | 11.1 |

**Classical Wave Bits
With Bearing**



| ITEM NO. | SHANK DIA. | CUTTER DIA. | CUTTING LENGTH | CUTTING WIDTH |
|----------|------------|-------------|----------------|---------------|
| 5356 | 6 | 38.1 | 19.1 | 12.7 |
| 5357 | 8 | 38.1 | 19.1 | 12.7 |
| 5361 | 12 | 38.1 | 19.1 | 12.7 |

**Classical Ogee Bits I
With Bearing**

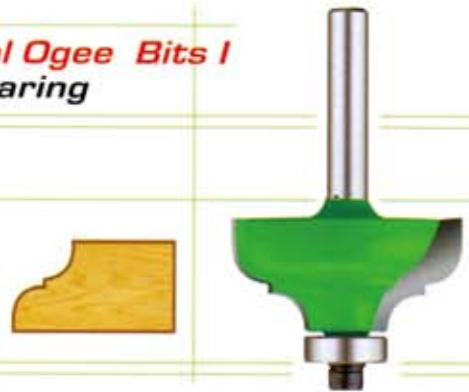

| ITEM NO. | SHANK DIA. | CUTTER DIA. | CUTTING LENGTH | RADIUS 1 | RADIUS 2 |
|----------|------------|-------------|----------------|----------|----------|
| 5381 | 6 | 28.6 | 12.7 | 4.0 | 4.0 |
| 5382 | 6 | 34.9 | 17.5 | 5.5 | 5.5 |
| 5396 | 8 | 28.6 | 12.7 | 4.0 | 4.0 |
| 5397 | 8 | 34.9 | 17.5 | 5.5 | 5.5 |
| 5411 | 12 | 28.6 | 12.7 | 4.0 | 4.0 |
| 5412 | 12 | 34.9 | 17.5 | 5.5 | 5.5 |

**Classical Bold Bit
With Bearing**



| ITEM NO. | SHANK DIA. | CUTTER DIA. | CUTTING LENGTH | CUTTING WIDTH |
|----------|------------|-------------|----------------|---------------|
| 5371 | 12 | 38.1 | 28.6 | 12.7 |

Classical Palace Bits

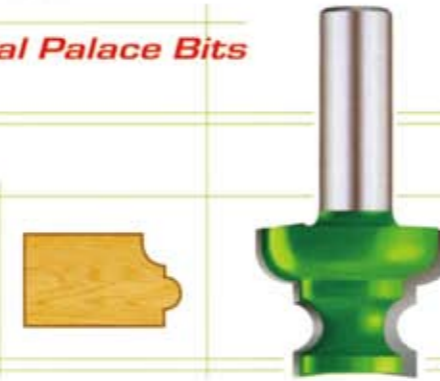

| ITEM NO. | SHANK DIA. | CUTTER DIA. | CUTTING LENGTH | d. |
|----------|------------|-------------|----------------|------|
| 5401 | 12 | 28.6 | 19.1 | 6.35 |
| 5402 | 12 | 34.9 | 25.4 | 7.9 |
| 5403 | 12 | 41.3 | 33.3 | 9.5 |

**Face Moulding Bits
With Bearing**



| ITEM NO. | SHANK DIA. | CUTTER DIA. | CUTTING LENGTH |
|----------|------------|-------------|----------------|
| 5421 | 12 | 27 | 44 |
| 5422 | 12 | 23.8 | 36.4 |
| 5423 | 12 | 23.8 | 34.9 |

Crown Moulding Bits I

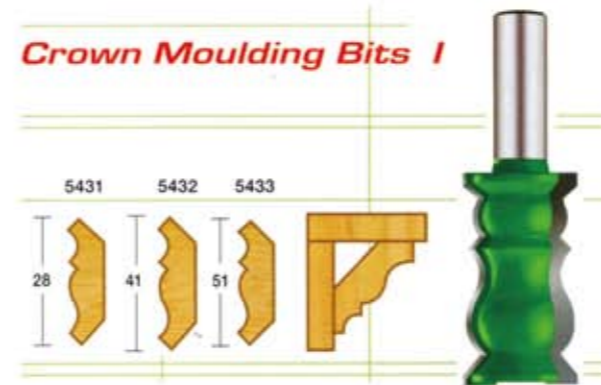

| ITEM NO. | SHANK DIA. | CUTTER DIA. | CUTTING LENGTH |
|----------|------------|-------------|----------------|
| 5431 | 12 | 28.6 | 38.1 |
| 5432 | 12 | 28.6 | 38.1 |
| 5433 | 12 | 30.2 | 38.1 |

Crown Moulding Bits II

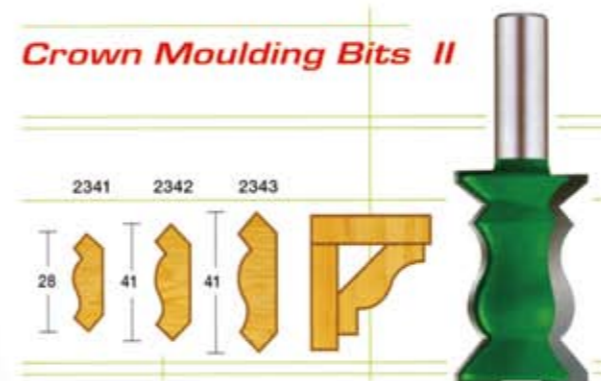

| ITEM NO. | SHANK DIA. | CUTTER DIA. | CUTTING LENGTH |
|----------|------------|-------------|----------------|
| 5446 | 12 | 28.6 | 38.1 |
| 5447 | 12 | 28.6 | 38.1 |
| 5448 | 12 | 30.2 | 38.1 |

Cove Moulding Bits



| ITEM NO. | SHANK DIA. | CUTTER DIA. | CUTTING LENGTH | RADIUS |
|----------|------------|-------------|----------------|--------|
| 5451 | 12 | 22.2 | 38.1 | 12.7 |
| 5452 | 12 | 25.4 | 41.3 | 19.1 |
| 5453 | 12 | 28.6 | 47.6 | 30.2 |
| 5454 | 12 | 28.6 | 57.2 | 47.6 |

**Multiform Bit I
With Bearing**

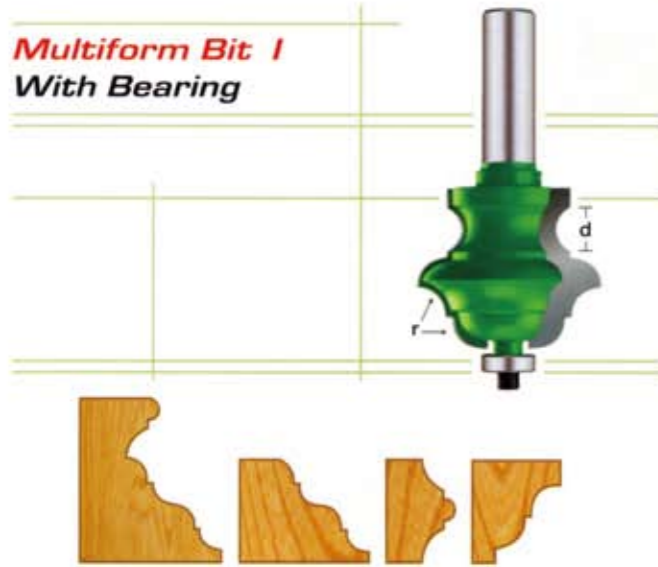

| ITEM NO. | SHANK DIA. | CUTTER DIA. | CUTTING LENGTH | r. | d. |
|----------|------------|-------------|----------------|-----|-----|
| 5461 | 12 | 44.50 | 38.1 | 7.2 | 9.5 |

**Multiform Bit II
With Bearing**



| ITEM NO. | SHANK DIA. | CUTTER DIA. | CUTTING LENGTH | CUTTING WIDTH |
|----------|------------|-------------|----------------|---------------|
| 5501 | 12 | 44.50 | 30.2 | 12.7 |

**Ogee Bits
With Bearing**

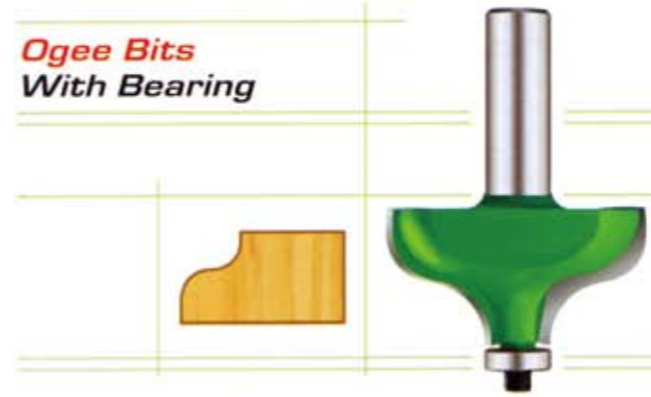

| ITEM NO. | SHANK DIA. | CUTTER DIA. | CUTTING LENGTH | RADIUS 1 | RADIUS 2 |
|----------|------------|-------------|----------------|----------|----------|
| 5471 | 6 | 28.6 | 12.7 | 4.5 | 4.0 |
| 5486 | 8 | 28.6 | 12.7 | 4.5 | 4.0 |
| 5487 | 8 | 34.9 | 17.5 | 6.0 | 5.0 |
| 5501 | 12 | 28.6 | 12.7 | 4.5 | 4.0 |
| 5502 | 12 | 34.9 | 17.5 | 6.0 | 5.0 |

**Roman Ogee / Round Nose Bit
With Bearing**



| ITEM NO. | SHANK DIA. | CUTTER DIA. | CUTTING LENGTH | CUTTING WIDTH |
|----------|------------|-------------|----------------|---------------|
| 5511 | 12 | 50.8 | 22.2 | 19.1 |

**Double Cove And Bead Bit
With Bearing**

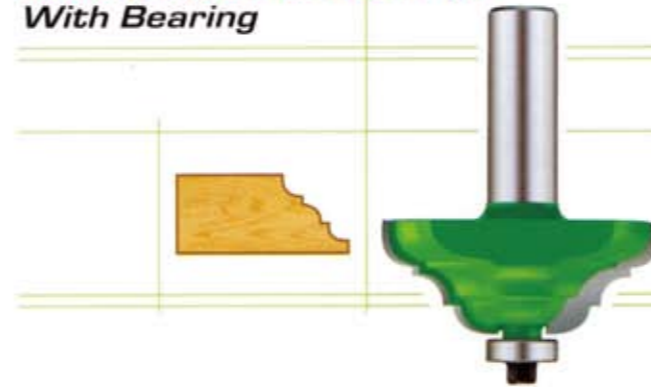

| ITEM NO. | SHANK DIA. | CUTTER DIA. | CUTTING LENGTH | CUTTING WIDTH |
|----------|------------|-------------|----------------|---------------|
| 5521 | 12 | 50.8 | 19.1 | 19.1 |

**Hinge Boring Bits
With Centering Pointed Toe**

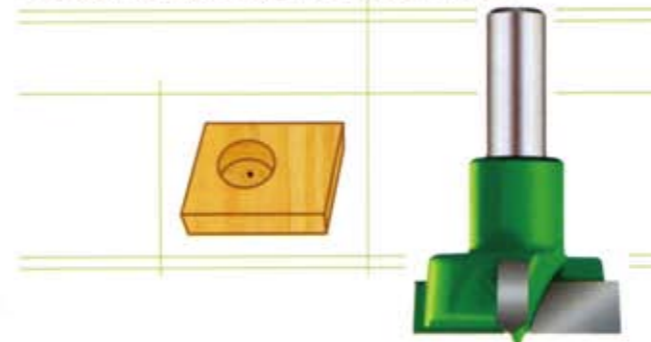

| ITEM NO. | SHANK DIA. | CUTTER DIA. | TOTAL LENGTH |
|----------|------------|-------------|--------------|
| 6261 | 10 | 20 | 90 |
| 6262 | 10 | 25 | 90 |
| 6263 | 10 | 30 | 90 |
| 6264 | 10 | 35 | 90 |
| 6265 | 10 | 40 | 90 |

**Raised Panel Bits
With Bearing**

6371/6372

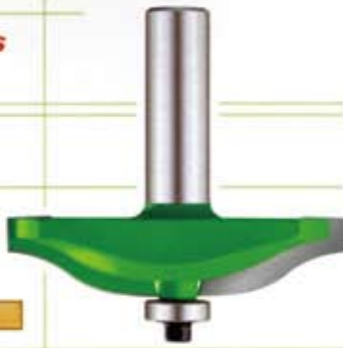

6351/6352



6361/6362



6381/6382



6391/6392

• 5° FACE CUT

| ITEM NO. | SHANK DIA. | CUTTER DIA. | CUTTING LENGTH | CUTTING WIDTH |
|----------|------------|-------------|----------------|---------------|
| 6351 | 12 | 66.7 | 12.7 | 27 |
| 6352 | 12 | 88.9 | 14.3 | 38.1 |

• 15° FACE CUT

| ITEM NO. | SHANK DIA. | CUTTER DIA. | CUTTING LENGTH | CUTTING WIDTH |
|----------|------------|-------------|----------------|---------------|
| 6361 | 12 | 66.7 | 11.1 | 27 |
| 6362 | 12 | 88.9 | 14.3 | 38.1 |

• OGEE

| ITEM NO. | SHANK DIA. | CUTTER DIA. | CUTTING LENGTH | CUTTING WIDTH |
|----------|------------|-------------|----------------|---------------|
| 6371 | 12 | 66.7 | 12.7 | 27 |
| 6372 | 12 | 88.9 | 14.3 | 38.1 |

• 12° FACE AND QUARTER ROUND

| ITEM NO. | SHANK DIA. | CUTTER DIA. | CUTTING LENGTH | CUTTING WIDTH |
|----------|------------|-------------|----------------|---------------|
| 6381 | 12 | 66.7 | 11.1 | 27 |
| 6382 | 12 | 88.9 | 14.3 | 38.1 |

• CONVEX

| ITEM NO. | SHANK DIA. | CUTTER DIA. | CUTTING LENGTH | CUTTING WIDTH |
|----------|------------|-------------|----------------|---------------|
| 6391 | 12 | 66.7 | 12.7 | 27 |
| 6392 | 12 | 88.9 | 14.3 | 38.1 |

**Raised Panel Bits
With Under Cutter & Bearing**

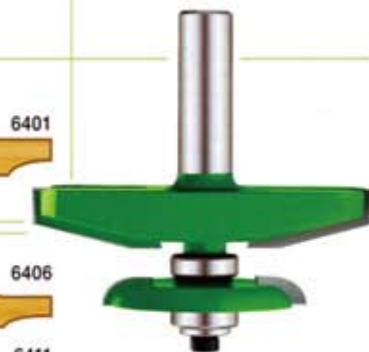

6401



6406



6411



6416



6421

• 5° FACE CUT

| ITEM NO. | SHANK DIA. | CUTTER DIA. | CUTTING LENGTH | CUTTING WIDTH |
|----------|------------|-------------|----------------|---------------|
| 6401 | 12 | 79.4 | 12.7 | 31.8 |

• 15° FACE CUT

| ITEM NO. | SHANK DIA. | CUTTER DIA. | CUTTING LENGTH | CUTTING WIDTH |
|----------|------------|-------------|----------------|---------------|
| 6406 | 12 | 79.4 | 12.7 | 31.8 |

• OGEE

| ITEM NO. | SHANK DIA. | CUTTER DIA. | CUTTING LENGTH | CUTTING WIDTH |
|----------|------------|-------------|----------------|---------------|
| 6411 | 12 | 79.4 | 12.7 | 31.8 |

• 12° FACE AND QUARTER ROUND

| ITEM NO. | SHANK DIA. | CUTTER DIA. | CUTTING LENGTH | CUTTING WIDTH |
|----------|------------|-------------|----------------|---------------|
| 6416 | 12 | 79.4 | 12.7 | 31.8 |

• CONVEX

| ITEM NO. | SHANK DIA. | CUTTER DIA. | CUTTING LENGTH | CUTTING WIDTH |
|----------|------------|-------------|----------------|---------------|
| 6421 | 12 | 79.4 | 12.7 | 31.8 |

Rosettee Cutters



6439

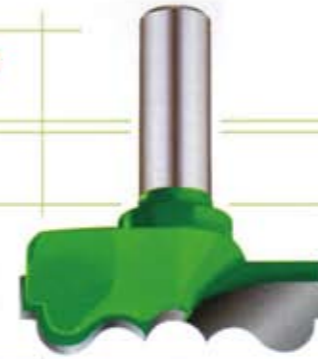

6431



6432



6433



6434



6435



6436



6437



6438



6440

| ITEM NO. | SHANK DIA. | CUTTER DIA. |
|----------|------------|-------------|
| 6431 | 12 | 54 |
| 6432 | 12 | 54 |
| 6433 | 12 | 54 |
| 6434 | 12 | 54 |
| 6435 | 12 | 54 |
| 6436 | 12 | 54 |
| 6437 | 12 | 54 |
| 6438 | 12 | 54 |
| 6439 | 12 | 54 |
| 6440 | 12 | 54 |

**One Piece Stile And Rail
With Bearing**

6251



6252



6253



6254



| ITEM NO. | DESCRIPTION | SHANK DIA. | CUTTER DIA. | CUTTING LENGTH |
|----------|---------------|------------|-------------|----------------|
| 6251 | QUARTER ROUND | 12 | 41.3 | 20.7 |
| 6252 | BEAD | 12 | 41.3 | 20.7 |
| 6253 | ROMAN OGEE | 12 | 41.3 | 20.7 |
| 6254 | OGEE | 12 | 41.3 | 20.7 |

Reversible Stile & Rail With Bearing

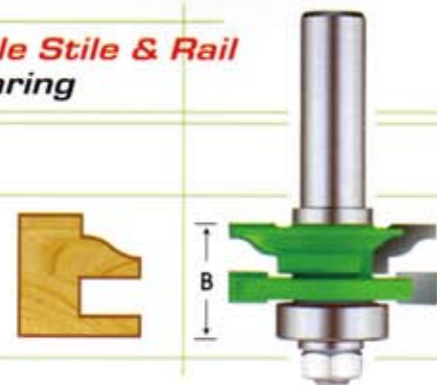

| ITEM NO. | SHANK DIA. | DESCRIPTION | CUTTER DIA. | B |
|----------|------------|-------------|-------------|------|
| 6481 | 8 | ROMAN OGEE | 41.3 | 22.2 |
| 6482 | 8 | OGEE | 41.3 | 22.2 |
| 6483 | 8 | BEVELED | 41.3 | 22.2 |
| 6484 | 8 | CLASSICAL | 41.3 | 22.2 |

Reversible Stile & Rail With Bearing



| ITEM NO. | SHANK DIA. | DESCRIPTION | CUTTER DIA. | CUTTING LENGTH |
|----------|------------|-------------|-------------|----------------|
| 6291 | 12 | ROMAN OGEE | 41.3 | 20.7 |
| 6292 | 12 | OGEE | 41.3 | 20.7 |
| 6293 | 12 | BEVELED | 41.3 | 20.7 |
| 6294 | 12 | CLASSICAL | 41.3 | 20.7 |

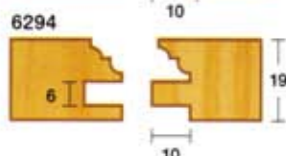
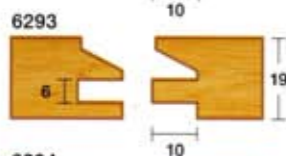
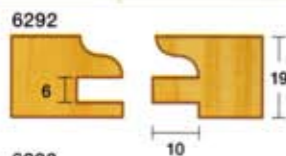
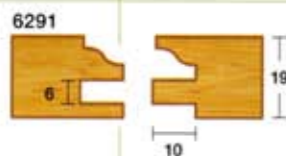

2-piece Stile & Rail Sets With Bearing

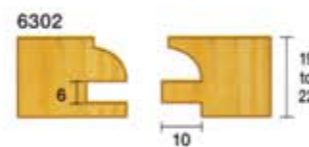
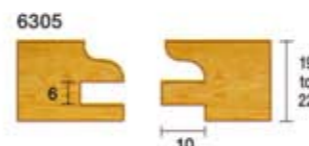
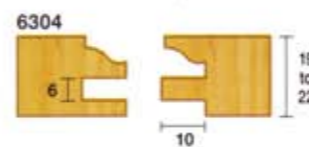
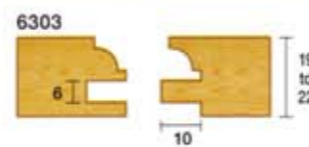
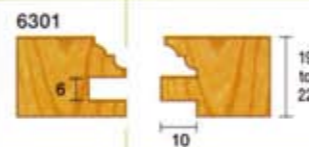

Profile Scriber Multi Set



| ITEM NO. | SHANK DIA. | DESCRIPTION | CUTTER DIA. | CUTTING LENGTH |
|----------|------------|---------------|-------------|----------------|
| 6301 | 12 | CLASSICAL | 44.50 | 28.6 |
| 6302 | 12 | QUARTER ROUND | 44.50 | 28.6 |
| 6303 | 12 | QUARTER BEAD | 44.50 | 28.6 |
| 6304 | 12 | ROMAN OGEE | 44.50 | 28.6 |
| 6305 | 12 | OGEE | 44.50 | 28.6 |

LET YOU MAKE TONGUE AND GROOVE AND THREE DIFFERENT TYPES OF STILE & RAIL - ROMAN OGEE, BEVELED, AND CLASSICAL. COMPLETE SET INCLUDES 3 PROFILE BLOCKS, 2 SLOTTERS, 1 ARBOR, 2 BEARINGS, AND SHIM SET.

| ITEM NO. | SHANK DIA. | CUTTER DIA. | B |
|----------|------------|-------------|------|
| 6241 | 8 | 41.3 | 22.2 |

Window Sash Sets With Bearing

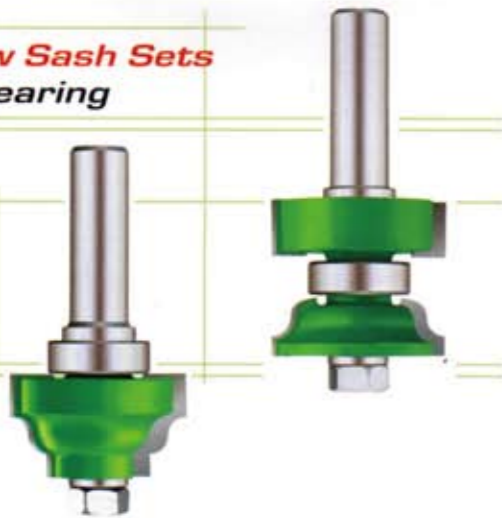

• **BEAD**

| ITEM NO. | SHANK DIA. | CUTTER DIA. | CUTTING LENGTH |
|----------|------------|-------------|----------------|
| 6321 | 12 | 38.1 | 22.2 |
| 6322 | 12 | 38.1 | 34.9 |

• **OGEE**

| ITEM NO. | SHANK DIA. | CUTTER DIA. | CUTTING LENGTH |
|----------|------------|-------------|----------------|
| 6331 | 12 | 38.1 | 22.2 |
| 6332 | 12 | 38.1 | 34.9 |

Internal Radius Bits

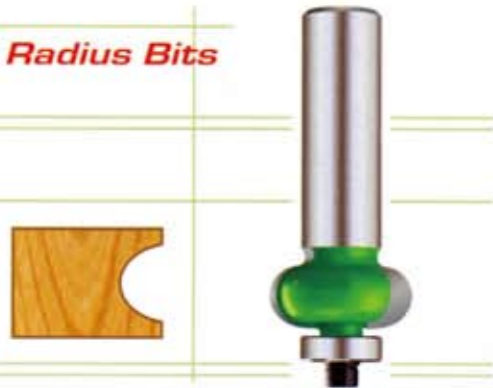

| ITEM NO. | SHANK DIA. | CUTTER DIA. | CUTTING LENGTH | RADIUS |
|----------|------------|-------------|----------------|--------|
| 6211 | 6 | 22.2 | 9.5 | 4.8 |
| 6212 | 6 | 22.2 | 12.7 | 6.35 |
| 6213 | 6 | 25.4 | 19 | 9.5 |
| 6221 | 12 | 22.2 | 9.5 | 4.8 |
| 6222 | 12 | 22.2 | 12.7 | 6.35 |
| 6223 | 12 | 22.2 | 19 | 9.5 |
| 6224 | 12 | 25.4 | 25.4 | 15.9 |
| 6225 | 12 | 28.6 | 38.1 | 28.6 |

Finger Pull Bits

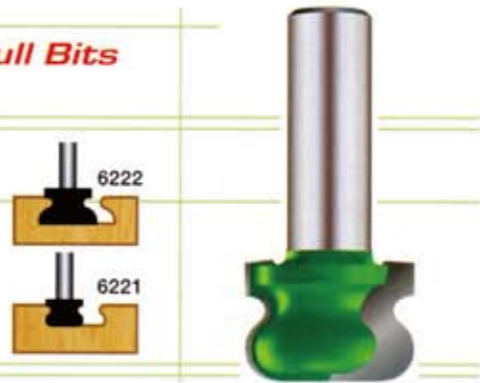

| ITEM NO. | SHANK DIA. | CUTTER DIA. | CUTTING LENGTH |
|----------|------------|-------------|----------------|
| 6221 | 12 | 25.4 | 19.1 |
| 6222 | 12 | 34.9 | 19.1 |

Door Lip Bits

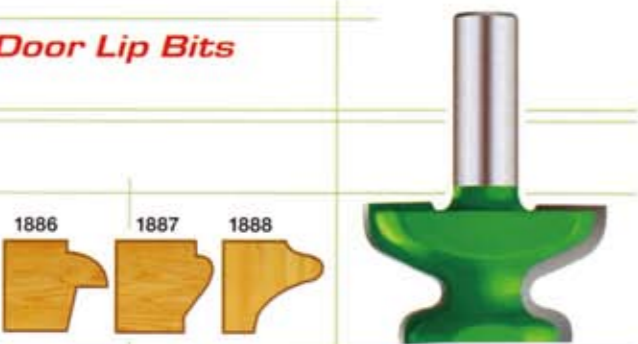

| ITEM NO. | SHANK DIA. | CUTTER DIA. | CUTTING LENGTH |
|----------|------------|-------------|----------------|
| 6231 | 12 | 41.3 | 31.8 |
| 6232 | 12 | 33.3 | 25.4 |
| 6233 | 12 | 47.6 | 25.4 |

Number Index

| | | | | | | | | | | | | | | | | | | | |
|------|----|------|----|------|----|------|----|------|----|------|----|------|----|------|----|------|----|------|----|
| 4062 | 01 | 4215 | 02 | 4391 | 03 | 4640 | 05 | 5079 | 09 | 5957 | 10 | 5123 | 12 | 4663 | 15 | 4582 | 19 | 6262 | 24 |
| 4064 | 01 | 4216 | 02 | 4392 | 03 | 4641 | 05 | 5080 | 09 | 5966 | 10 | 5124 | 12 | 4664 | 15 | 4583 | 19 | 6263 | 24 |
| 4066 | 01 | 4217 | 02 | 4393 | 03 | 4831 | 05 | 5081 | 09 | 5967 | 10 | 5125 | 12 | 4665 | 15 | 4584 | 19 | 6264 | 24 |
| 4067 | 01 | 4218 | 02 | 4394 | 03 | 4841 | 06 | 5082 | 09 | 5968 | 10 | 5128 | 12 | 4666 | 15 | 5891 | 19 | 6265 | 24 |
| 4068 | 01 | 4219 | 02 | 4091 | 03 | 4842 | 06 | 5083 | 09 | 5969 | 10 | 5141 | 12 | 4667 | 15 | 5892 | 19 | 6351 | 25 |
| 4069 | 01 | 4221 | 02 | 4092 | 03 | 4843 | 06 | 5084 | 09 | 5970 | 10 | 4736 | 12 | 4668 | 15 | 5896 | 19 | 6352 | 25 |
| 4070 | 01 | 4222 | 02 | 4093 | 03 | 4844 | 06 | 5085 | 09 | 5971 | 10 | 4737 | 12 | 4676 | 15 | 5897 | 19 | 6361 | 25 |
| 4072 | 01 | 4223 | 02 | 4101 | 03 | 4845 | 06 | 5086 | 09 | 5972 | 10 | 4738 | 12 | 4677 | 15 | 5901 | 19 | 6362 | 25 |
| 4073 | 01 | 4224 | 02 | 4102 | 03 | 4846 | 06 | 5101 | 09 | 5981 | 10 | 4751 | 12 | 4678 | 15 | 5902 | 19 | 6371 | 25 |
| 4074 | 01 | 4226 | 02 | 4103 | 03 | 4861 | 06 | 5102 | 09 | 5982 | 10 | 4752 | 12 | 5621 | 15 | 6001 | 19 | 6372 | 25 |
| 4076 | 01 | 4227 | 02 | 4151 | 03 | 4862 | 06 | 5103 | 09 | 5983 | 10 | 4753 | 12 | 5622 | 15 | 6011 | 20 | 6381 | 25 |
| 4078 | 01 | 4228 | 02 | 4156 | 03 | 4863 | 06 | 5104 | 09 | 5984 | 10 | 4754 | 12 | 5623 | 15 | 6012 | 20 | 6382 | 25 |
| 4079 | 01 | 4229 | 02 | 4171 | 03 | 4864 | 06 | 5551 | 09 | 5985 | 10 | 4755 | 12 | 5624 | 15 | 6041 | 20 | 6391 | 25 |
| 4081 | 01 | 4230 | 02 | 4172 | 03 | 4865 | 06 | 5561 | 09 | 5986 | 10 | 4756 | 12 | 5625 | 15 | 6042 | 20 | 6392 | 25 |
| 4082 | 01 | 4231 | 02 | 4173 | 03 | 4866 | 06 | 5562 | 09 | 6026 | 10 | 4766 | 12 | 5626 | 15 | 6051 | 20 | 6401 | 25 |
| 4083 | 01 | 4001 | 02 | 4291 | 04 | 4867 | 06 | 5563 | 09 | 6027 | 10 | 4767 | 12 | 5646 | 15 | 6052 | 20 | 6406 | 25 |
| 4084 | 01 | 4002 | 02 | 4292 | 04 | 4881 | 06 | 5564 | 09 | 6028 | 10 | 4768 | 12 | 5647 | 15 | 5191 | 20 | 6411 | 25 |
| 4085 | 01 | 4003 | 02 | 4293 | 04 | 4882 | 06 | 5565 | 09 | 6029 | 10 | 4769 | 12 | 5648 | 15 | 5271 | 20 | 6416 | 25 |
| 4111 | 01 | 4011 | 02 | 4296 | 04 | 4883 | 06 | 5566 | 09 | 5681 | 11 | 4770 | 12 | 5649 | 15 | 5272 | 20 | 6421 | 25 |
| 4113 | 01 | 4012 | 02 | 4297 | 04 | 4884 | 06 | 5567 | 09 | 5696 | 11 | 4771 | 12 | 5650 | 15 | 5273 | 20 | 6431 | 26 |
| 4114 | 01 | 4013 | 02 | 4423 | 04 | 4885 | 06 | 5568 | 09 | 5697 | 11 | 4301 | 13 | 5651 | 15 | 5274 | 20 | 6432 | 26 |
| 4115 | 01 | 4021 | 02 | 4424 | 04 | 4886 | 06 | 5569 | 09 | 5698 | 11 | 4302 | 13 | 5652 | 15 | 5281 | 20 | 6433 | 26 |
| 4116 | 01 | 4022 | 02 | 4451 | 04 | 4887 | 06 | 5581 | 09 | 5699 | 11 | 4311 | 13 | 5653 | 15 | 5282 | 20 | 6434 | 26 |
| 4117 | 01 | 4031 | 02 | 4452 | 04 | 4888 | 06 | 5582 | 09 | 5701 | 11 | 4312 | 13 | 5671 | 15 | 5331 | 21 | 6435 | 26 |
| 4118 | 01 | 4032 | 02 | 4453 | 04 | 4891 | 06 | 5583 | 09 | 5702 | 11 | 4321 | 13 | 5672 | 15 | 5332 | 21 | 6436 | 26 |
| 4119 | 01 | 4033 | 02 | 4454 | 04 | 4251 | 06 | 5584 | 09 | 5716 | 11 | 4322 | 13 | 5673 | 15 | 5333 | 21 | 6437 | 26 |
| 4120 | 01 | 4041 | 02 | 4455 | 04 | 4252 | 06 | 5601 | 09 | 5717 | 11 | 4901 | 13 | 5674 | 15 | 5337 | 21 | 6438 | 26 |
| 4121 | 01 | 4042 | 02 | 4456 | 04 | 4261 | 07 | 5602 | 09 | 5718 | 11 | 4902 | 13 | 5675 | 15 | 5341 | 21 | 6439 | 26 |
| 4122 | 01 | 4043 | 02 | 4457 | 04 | 4271 | 07 | 5603 | 09 | 5719 | 11 | 4903 | 13 | 5676 | 15 | 5342 | 21 | 6440 | 26 |
| 4123 | 01 | 4051 | 02 | 4458 | 04 | 4272 | 07 | 5604 | 09 | 5720 | 11 | 4916 | 13 | 5677 | 15 | 5356 | 21 | 6251 | 26 |
| 4124 | 01 | 4052 | 02 | 4481 | 04 | 4281 | 07 | 5605 | 09 | 5721 | 11 | 4917 | 13 | 5678 | 15 | 5357 | 21 | 6252 | 26 |
| 4125 | 01 | 4053 | 02 | 4482 | 04 | 4361 | 08 | 5606 | 09 | 5736 | 11 | 4918 | 13 | 5611 | 16 | 5361 | 21 | 6253 | 26 |
| 4126 | 01 | 4141 | 02 | 4483 | 04 | 4362 | 08 | 5607 | 09 | 5737 | 11 | 4931 | 13 | 5816 | 16 | 5381 | 21 | 6254 | 26 |
| 4127 | 01 | 4142 | 02 | 4556 | 04 | 4371 | 08 | 5608 | 09 | 5738 | 11 | 4932 | 13 | 5821 | 16 | 5382 | 21 | 6481 | 27 |
| 4129 | 01 | 4143 | 02 | 4557 | 04 | 4372 | 08 | 5609 | 09 | 5739 | 11 | 4933 | 13 | 5831 | 16 | 5396 | 21 | 6482 | 27 |
| 4130 | 01 | 4161 | 02 | 4558 | 04 | 4373 | 08 | 5201 | 10 | 5740 | 11 | 4946 | 14 | 5851 | 16 | 5397 | 21 | 6483 | 27 |
| 4131 | 01 | 4162 | 02 | 4559 | 04 | 4781 | 08 | 5202 | 10 | 5741 | 11 | 4947 | 14 | 5911 | 17 | 5411 | 21 | 6484 | 27 |
| 4132 | 01 | 4163 | 02 | 4571 | 04 | 4782 | 08 | 5203 | 10 | 5763 | 11 | 4961 | 14 | 5912 | 17 | 5412 | 21 | 6291 | 27 |
| 4133 | 01 | 4164 | 02 | 4572 | 04 | 4783 | 08 | 5204 | 10 | 5764 | 11 | 4962 | 14 | 6071 | 17 | 5371 | 21 | 6292 | 27 |
| 4134 | 01 | 4341 | 03 | 4573 | 04 | 4784 | 08 | 5211 | 10 | 5765 | 11 | 4963 | 14 | 6072 | 17 | 5401 | 22 | 6293 | 27 |
| 4135 | 01 | 4342 | 03 | 4574 | 04 | 4785 | 08 | 5212 | 10 | 5766 | 11 | 4976 | 14 | 6081 | 17 | 5402 | 22 | 6294 | 27 |
| 4136 | 01 | 4343 | 03 | 6451 | 04 | 4786 | 08 | 5213 | 10 | 5767 | 11 | 4977 | 14 | 6086 | 17 | 5403 | 22 | 6301 | 28 |
| 4137 | 01 | 4344 | 03 | 6452 | 04 | 4787 | 08 | 5214 | 10 | 5768 | 11 | 4978 | 14 | 6091 | 17 | 5421 | 22 | 6302 | 28 |
| 4191 | 01 | 4345 | 03 | 6461 | 04 | 4801 | 08 | 5221 | 10 | 5769 | 11 | 4991 | 14 | 6101 | 17 | 5422 | 22 | 6303 | 28 |
| 4193 | 01 | 4346 | 03 | 6462 | 04 | 4802 | 08 | 5222 | 10 | 5770 | 11 | 5001 | 14 | 6106 | 17 | 5423 | 22 | 6304 | 28 |
| 4194 | 01 | 4348 | 03 | 6471 | 04 | 4803 | 08 | 5223 | 10 | 5771 | 11 | 5011 | 14 | 6121 | 17 | 5431 | 22 | 6305 | 28 |
| 4195 | 01 | 4349 | 03 | 6472 | 04 | 4804 | 08 | 5224 | 10 | 5772 | 11 | 5021 | 14 | 6122 | 17 | 5432 | 22 | 6241 | 28 |
| 4196 | 01 | 4350 | 03 | 6131 | 05 | 4805 | 08 | 5231 | 10 | 5781 | 11 | 5031 | 14 | 5801 | 18 | 5433 | 22 | 6321 | 29 |
| 4197 | 01 | 4351 | 03 | 6136 | 05 | 4806 | 08 | 5232 | 10 | 5782 | 11 | 5042 | 14 | 5806 | 18 | 5446 | 22 | 6322 | 29 |
| 4198 | 01 | 4352 | 03 | 6201 | 05 | 4807 | 08 | 5233 | 10 | 5783 | 11 | 5161 | 14 | 5991 | 18 | 5447 | 22 | 6331 | 29 |
| 4199 | 01 | 4353 | 03 | 4601 | 05 | 4821 | 08 | 5234 | 10 | 5784 | 11 | 5171 | 14 | 4501 | 18 | 5448 | 22 | 6332 | 29 |
| 4200 | 01 | 4354 | 03 | 4602 | 05 | 4822 | 08 | 5241 | 10 | 5785 | 11 | 5181 | 14 | 4506 | 18 | 5451 | 23 | 6211 | 29 |
| 4201 | 01 | 4355 | 03 | 4603 | 05 | 4823 | 08 | 5242 | 10 | 5786 | 11 | 4701 | 15 | 4507 | 18 | 5452 | 23 | 6212 | 29 |
| 4202 | 01 | 4356 | 03 | 4604 | 05 | 4824 | 08 | 5243 | 10 | 5787 | 11 | 4702 | 15 | 4508 | 18 | 5453 | 23 | 6213 | 29 |
| 4203 | 01 | 4357 | 03 | 4616 | 05 | 4825 | 08 | 5244 | 10 | 5861 | 12 | 4703 | 15 | 4521 | 18 | 5454 | 23 | 6221 | 29 |
| 4204 | 01 | 4381 | 03 | 4617 | 05 | 4826 | 08 | 5251 | 10 | 5862 | 12 | 4706 | 15 | 4522 | 18 | 5461 | 23 | 6222 | 29 |
| 4205 | 01 | 4382 | 03 | 4631 | 05 | 4851 | 08 | 5252 | 10 | 5871 | 12 | 4707 | 15 | 4531 | 18 | 5501 | 23 | 6223 | 29 |
| 4207 | 01 | 4383 | 03 | 4632 | 05 | 5051 | 09 | 5253 | 10 | 5872 | 12 | 4708 | 15 | 4532 | 18 | 5471 | 24 | 6224 | 29 |
| 4208 | 01 | 4384 | 03 | 4633 | 05 | 5052 | 09 | 5254 | 10 | 5881 | 12 | 4711 | 15 | 4541 | 19 | 5486 | 24 | 6225 | 29 |
| 4209 | 01 | 4385 | 03 | 4634 | 05 | 5053 | 09 | 5951 | 10 | 5882 | 12 | 4712 | 15 | 4546 | 19 | 5487 | 24 | 6221 | 29 |
| 4210 | 01 | 4386 | 03 | 4635 | 05 | 5054 | 09 | 5952 | 10 | 5883 | 12 | 4713 | 15 | 4547 | 19 | 5501 | 24 | 6222 | 29 |
| 4211 | 01 | 4387 | 03 | 4636 | 05 | 5055 | 09 | 5953 | 10 | 5884 | 12 | 4714 | 15 | 4561 | 19 | 5502 | 24 | 6231 | 29 |
| 4212 | 01 | 4388 | 03 | 4637 | 05 | 5076 | | | | | | | | | | | | | |

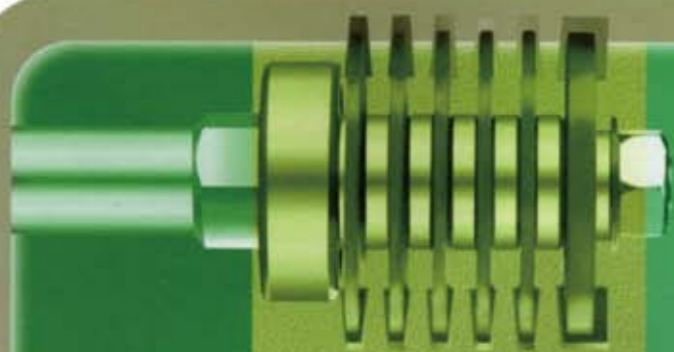

ROUTER BITS



EZ

ROUTER BITS m/m

CUT



I'm your best partner
to work with !



EZCUT®

SEN YEONG PRECISION TOOL CO., LTD.

N0.68, Jen-Mei Rd., Ta-Li, Taichung, Taiwan, R.O.C.

Tel : 886-4-24918305 • 24918306 • 24918309 Fax : 886-4-24914189

[http : //www.sen-yeong.com](http://www.sen-yeong.com)

E-mail : seyeong@ms18.hinet.net